

# Information DISPLAY

July 2003  
Vol. 19, No. 7

Official Monthly Publication of the Society for Information Display

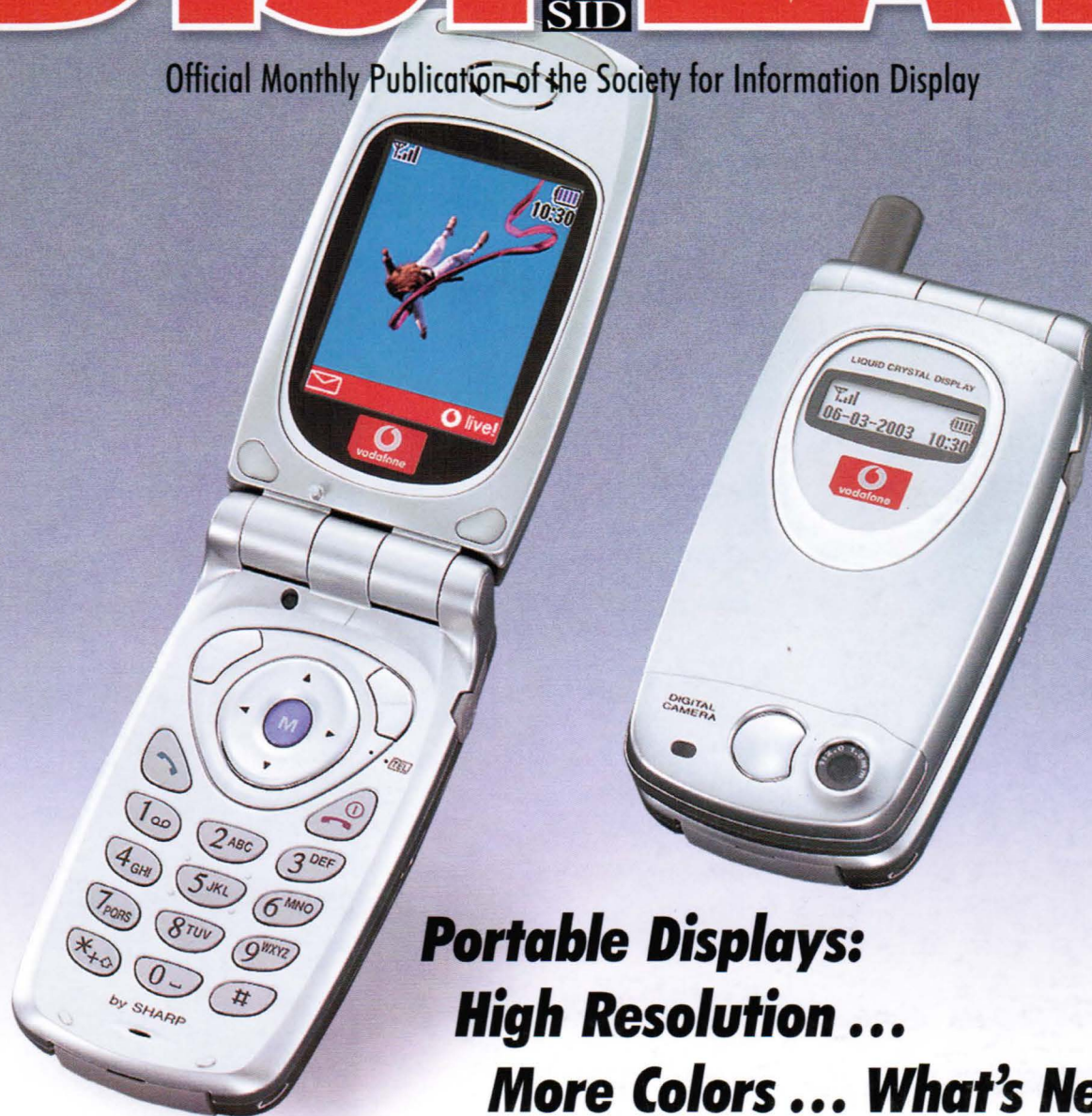

**Portable Displays:  
High Resolution ...  
More Colors ... What's Next?**

- ***In Pursuit of System LCDs***
- ***Designing Touch LCDs***
- ***RotoView™: A View-Navigation System***
- ***Automotive-Displays Update***
- ***AMLCDs for Mobile Phones in Japan***

SAMSUNG DIGITall  
everyone's invited.



## OUR TFT-LCD DISPLAYS ARE THE VERY PICTURE OF PERFORMANCE.

At Samsung, we're driving the visual revolution. As the world's leading supplier of flat-panel TFT-LCD displays, we deliver the most realistic colors and brilliant images to notebook PCs, monitors, TVs, and handheld consumer electronic devices. We have an extensive line of TFT-LCDs specifically designed for the most demanding industrial applications. Incorporating our patented Patterned Vertical Alignment™ technology, our TFT-LCD displays achieve the highest contrast ratios and fastest response times in the industry. Whether your customers surf the wireless Web, create 3D graphics or just spend hours in front of a digital TV, Samsung has the high-performance TFT-LCD solution you're looking for.

**FRAME SOLD SEPARATELY.**



SEMICONDUCTOR

[www.usa.samsungsemi.com](http://www.usa.samsungsemi.com)

Circle no. 1

# Information DISPLAY

JULY 2003  
VOL. 19, NO. 7

Consumers are demanding more from their cellular phones and PDAs, and that requires more advanced displays. Display makers are working hard to deliver, and we are now seeing small displays with higher resolution, more colors, longer battery life, and high visibility – not to mention integration of electronic components thanks to poly-Si and continuous-grain-silicon displays. And, for portable devices, the display-centric system interface can be as important as the display itself. In this issue of ID, our authors look at the state of the art and provide some design guidance.



Sharp

## Next Month in Information Display

Industry Directory Issue

- Directory of the Display Industry
- LCoS for Rear-Projection HDTV
- Preserving Patent Rights
- Four-Primary-Color LCDs
- CeBIT 2003 Report

INFORMATION DISPLAY (ISSN 0362-0972) is published eleven times a year for the Society for Information Display by Palisades Convention Management, 411 Lafayette Street, 2nd Floor, New York, NY 10003; Leonard H. Klein, President and CEO. EDITORIAL AND BUSINESS OFFICES: Jay Morreale, Managing Editor, Palisades Convention Management, 411 Lafayette Street, 2nd Floor, New York, NY 10003; telephone 212/460-9700. Send manuscripts to the attention of the Editor, ID, Director of Sales: Joanne Morgenthal, Palisades Convention Management, 411 Lafayette Street, 2nd Floor, New York, NY 10003; 212/460-9700. SID HEADQUARTERS, for correspondence on subscriptions and membership: Society for Information Display, 610 S. 2nd Street, San Jose, CA 95112; telephone 408/977-1013, fax -1531. SUBSCRIPTIONS: Information Display is distributed without charge to those qualified and to SID members as a benefit of membership (annual dues \$75.00). Subscriptions to others: U.S. & Canada: \$55.00 one year, \$7.50 single copy; elsewhere: \$85.00 one year, \$7.50 single copy. PRINTED by Sheridan Printing Company, Alpha, NJ 08865. Third-class postage paid at Easton, PA. PERMISSIONS: Abstracting is permitted with credit to the source. Libraries are permitted to photocopy beyond the limits of the U.S. copyright law for private use of patrons, providing a fee of \$2.00 per article is paid to the Copyright Clearance Center, 21 Congress Street, Salem, MA 01970 (reference serial code 0362-0972/03/\$1.00 + \$0.00). Instructors are permitted to photocopy isolated articles for noncommercial classroom use without fee. This permission does not apply to any special reports or lists published in this magazine. For other copying, reprint or republication permission, write to Society for Information Display, 610 S. Second Street, San Jose, CA 95112. Copyright © 2003 Society for Information Display. All rights reserved.

- 2 Editorial**  
*Baloney! And Other Stories from the USDC/Needham Investors Conference*  
Kenneth I. Werner
- 4 My Turn**  
*The Numbers Racket*  
Peter H. Putman
- 12 Sharp: In Pursuit of System LCDs**  
*Placing the display electronics – or even the system electronics – on the display substrate would revolutionize display-product design; Sharp is making its first “system LCD” products with its own CG Silicon technology.*  
Joel Pollack
- 18 Designing Touch LCDs for Portable Devices**  
*The enhanced functionality of portable devices has outpaced the user’s ability to view information, execute commands, and easily navigate through complicated menus. The solution is the integration of touch technology with a highly visible display.*  
Bruce DeVisser
- 22 A View-Navigation System for Hand-Held Portable Displays**  
*RotoView™ scrolling technology makes large virtual images accessible to small hand-held devices such as PDAs and mobile telephones.*  
David Y. Feinstein
- 26 Road Show**  
*New technologies and applications are expanding the role of displays in automobiles, helping to inform and entertain both drivers and passengers.*  
Robert L. Donofrio
- 30 Active-Matrix LCDs for Mobile Telephones in Japan**  
*The increasingly sophisticated functions of modern mobile telephones require the use of more advanced displays, and the Japanese market leads the way.*  
Ryoichi Watanabe and Osamu Tomita
- 42 Letters**
- 45 SID News**  
*The SID Senior Member Grade Committee announces more SID Senior Members.*
- 47 Sustaining Members**
- 47 Advertiser’s Index**
- 48 Backlight**  
*DuPont Displays: Forcing the Action*  
David Lieberman
- 48 Calendar of Display-Related Events**
- For Industry News, New Products, Forthcoming Articles, and Complete, Continually Updated Conference Calendar, see [www.sid.org](http://www.sid.org).**

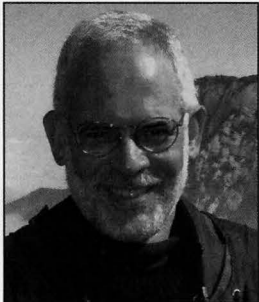

## Baloney! And Other Stories from the USDC/Needham Investors Conference

The USDC/Needham Display Industry Investors Conference was held in New York City on March 18, 2003, the day after Three-Five Systems (TFS) announced the spin-off of its microdisplay business into a separate company to be called Three-Five Microdisplay, Inc. (TFMD). So, when President and CEO Jack Saltich stepped to the podium to give the

TFS presentation instead of EVP Jeffrey Buchanan (as stated in the program), it was no surprise that he was speaking to a packed room.

Saltich was effective, saying that TFS today is really two separate companies: Integrated Systems and Displays (ISD), which is a service-oriented company, although it does sell products, and the LCoS business, which is still developing. Most of the company's losses have been in the LCoS business, not the core business. The company's strategy is to be a display-centric EMS provider, and recent acquisitions of a Boston-based GPS company and a Redmond-based systems-manufacturing company are furthering that goal, Saltich said.

Concerning TFMD, Saltich said he still believes that LCoS will be the next low-end HDTV technology, but the two businesses have different growth characteristics, different strategic parameters, different core deliverables, different markets and customers, and different employee skills and perspectives. "As separate companies, there will be many more degrees of freedom to exploit different strengths." The plan is for TFS to capitalize TFMD to the tune of approximately \$20 million and for Saltich to become Chairman of the Board. Bob Melcher will move over to TFMD to become CTO.

After his talk, I spoke with Saltich privately and asked him one question: "You delivered a graceful presentation, but there will be some skeptics who will say that the microdisplay business is a turkey and you are just trying to dump it. Comment?"

Saltich's answer began explosively: "Baloney! If I thought it was a turkey, I'd just close it down, not invest 25% of my cash in the new company and become its Chairman. We would have feathered down investment 12 months ago. I believe in this technology. Two years ago, I was less of a believer in NTE than I am now ... we now have customers." Saltich added that he is actively looking for a CFO for the new company.

### Investment in Displays?

The conference was well attended, and there seemed to be a real interest in display opportunities among the substantial investment contingent gathered at the Grand Hyatt Hotel. Several speakers quoted figures to the effect that displays accounted for a large percentage of the overall electronics market – nearly as large as semiconductors – and was the fastest growing segment, bar none.

I asked Jim Ricchiuti, a principal at Needham & Company, about the apparent excitement. He said that in a largely stagnant world economy, anything that's growing rapidly, as displays are, will capture the interest of the investment community. But institutional investors "are looking for investment opportunities in established display companies. Emerging companies are of much more limited appeal."

*continued on page 44*

## Information DISPLAY

**Editor:** Kenneth I. Werner  
**Managing Editor:** Jay Morreale  
**Administrative Editor:** Dian Mecca  
**Administrative Assistant:** Ralph Nadell  
**Contributing Editors:** David Lieberman, Bryan Norris, Alfred Poor,  
**Advertising Manager:** Jay Morreale  
**Sales Manager:** Joanne Morgenthal

### Regional Associate Editors

Allan Kmetz (**Americas**)  
*Chatham, New Jersey*  
 Shigeo Mikoshiba (**Asia**)  
*University of Electro-Communications  
 Tokyo, Japan*  
 Alan Mosley (**Europe**)  
*Central Research Laboratories  
 Hayes, Middlesex, U.K.*

### Advisory Editors

Carl Machover  
*Machover Associates  
 White Plains, New York*  
 Alan Sobel  
*Consultant  
 Evanston, Illinois*  
 Webster E. Howard  
*Lagrangeville, New York*  
 Ernst Lueder  
*University of Stuttgart  
 Stuttgart Germany*  
 Sungkyoo Lim  
*Information Display Research Center  
 Choongnam, Korea*

The opinions expressed in editorials, columns, and feature articles do not necessarily reflect the opinions of the editor or publisher of *Information Display Magazine*, nor do they necessarily reflect the position of the Society for Information Display.

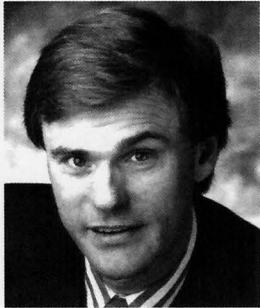

## The Numbers Racket

by Peter H. Putman, CTS

Pity the poor consumer. For years, buying a TV set meant buying a "TV" set, and nothing more. All one had to do is connect an antenna or cable, turn on the power, and start watching. Viewers didn't need to concern themselves with "native resolution" and "pixel decimation."

Thanks to a major transformation of television broadcasting, the days of analog 525- and 625-line interlaced-scan images are numbered. Replacing them will be several digital picture formats that offer as much and more resolution in two different screen shapes and sizes.

That's a lot for the average consumer to absorb, even after repeated visits to Best Buy and Circuit City. But there's another layer of complexity added with fixed-pixel displays. Now, our would-be TV buyer has to deal with different pixel counts; some of which match the new DTV standards, and some of which come out of left field.

In an attempt to clear things up, the Consumer Electronics Association has developed definitions for TV sets and monitors. As a result, we now have standard-definition TV (SDTV), enhanced-definition TV (EDTV), and high-definition TV (HDTV). These standards are based on specific scan-line counts, which ought to translate easily to fixed-pixel arrays.

While the difference between a monitor and TV is obvious (the latter has a built-in digital TV tuner), the differences between SDTV and EDTV are not so clear. Consider a 42-in. 16 x 9 plasma monitor with 852 x 480 pixels. Judging by vertical pixel count, it is an SDTV monitor. But horizontal pixel count of 852 is far more than a plain vanilla TV offers, so many folks consider this an EDTV monitor, particularly since it supports 480p, too.

Another puzzler: 42-in. plasma panels that employ 1024 x 768 non-square pixel matrices. Are these EDTV or HDTV monitors? Although 768 vertical pixels are certainly more than 720, 1024 horizontal pixels are less than 1280. And while a matrix of 1024 x 768 pixels produces a 4:3 picture aspect ratio, the screens on these monitors measure 16 x 9!

And what about the 32- and 42-in. ALiS plasma monitors and TVs sold by Sony, Fujitsu, and Hitachi that sport native pixel counts of 852 x 1024 and 1024 x 1024, respectively? Are these EDTV displays? HDTV? or something in the middle?

Do not look to the computer industry for help. That same 852 x 480 plasma monitor is known as a wide VGA (WVGA) in the computer world, not EDTV or SDTV. LCD and plasma monitors with 1280 x 768 and 1365 x 768 resolution are called wide XGA by the PC industry, not EDTV or HDTV. And 1024 x 768 monitors with non-square pixels are not even on their radar yet.

Most consumers will likely plug their ears and avoid this discussion altogether, particularly when they discover that any and all of these TVs and monitors can display HDTV signals, albeit with varying degrees of pixel decimation. And those pictures will look pretty darn good, too.

*continued on page 46*

### SID Executive Committee

President: A. Kmetz  
 President-Elect: S. Mikoshiba  
 Regional VP, Americas: M. Anandan  
 Regional VP, Asia: M. H. Oh  
 Regional VP, Europe: J-P. Budin  
 Treasurer: R. Seery  
 Secretary: P. Drzaic  
 Past President: A. Silzars

### Directors

Bay Area: N. Balram  
 Beijing: B. P. Wang  
 Belarus: A. Smirnov  
 Canada: T. C. Schmidt  
 Dayton: D. G. Hopper  
 Delaware Valley: J. W. Parker III  
 Detroit: R. L. Donofrio  
 France: M. Hareng  
 Hong Kong: H. Leung  
 India: K. R. Sarma  
 Japan: M. Maeda  
 Korea: M. K. Han  
 Los Angeles: P. C. Baron  
 Mid-Atlantic: A. Ghosh  
 Mid-Europe: J. Kimmel  
 Minneapolis/St. Paul: H. V. Hoepf  
 New England: W. A. Hamilton  
 Pacific Northwest: J. A. Rupp  
 Russia: V. V. Belyaev  
 San Diego: T. Iki  
 Singapore/Malaysia: B. A. Ghani  
 Southwest: P. A. Smith  
 Taipei: F-C. F. Luo  
 Texas: Z. Yaniv  
 U.K. & Ireland: A. Mosley  
 Ukraine: V. Sorokin

### Committee Chairs

Academic: H. Uchiike  
 Archives/Historian: D. Dumont  
 Bylaws: E. Lueder  
 Chapter Formation: B. Needham  
 Communications: H. Hoffman  
 Convention: P. M. Heyman  
 Definitions & Standards: D. Hopper  
 Honors & Awards: L. F. Weber  
 Long-Range Planning: T. Iki  
 Membership: R. Kessler  
 Nominations: A. Silzars  
 Publications: E. Stupp

### Chapter Chairs

Bay Area: M. F. Flynn  
 Beijing: J-L. Zhu  
 Belarus: S. Yakovenko  
 Canada: A. Kitai  
 Dayton: J. C. Byrd  
 Delaware Valley: S. Kalatucka, Jr.  
 Detroit: S. Pala  
 France: R. Meyer  
 Hong Kong: H. S. Kwok  
 India: S. Kaura  
 Japan: S. Naemura  
 Korea: L. S. Park  
 Los Angeles: M. L. Kesselman  
 Mid-Atlantic: V. R. Capozzi  
 Mid-Europe: N. Fruehauf  
 Minneapolis/St. Paul: E. L. Tomczak  
 New England: S. P. Atwood  
 Pacific Northwest: T. Voutsas  
 Russia: I. N. Kompanets  
 San Diego: A. R. Wilson  
 Singapore/Malaysia: X. Sun  
 Southwest: D. S. Lowe  
 Taipei: H.-P. D. Shieh  
 Texas: R. L. Fink  
 U.K. & Ireland: J. A. Raines  
 Ukraine: V. G. Sorokin

### Office Administration

Office and Data Manager: Jenny Needham

### Society for Information Display

610 S. 2nd Street  
 San Jose, CA 95112  
 408/977-1013, fax -1531  
 e-mail: office@sid.org  
 http://www.sid.org

# Sharp: In Pursuit of System LCDs

*Placing the display electronics – or even the system electronics – on the display substrate would revolutionize display-product design; Sharp is making its first “system LCD” products with its own CG Silicon technology.*

by Joel Pollack

**T**HE system liquid-crystal display (LCD) has come to be considered the ideal display component for high-performance mobile applications. By definition, a system LCD is manufactured to combine a number of components currently fabricated as discrete elements onto a single LCD glass substrate. These components may include the LCD driver, I/O, CPU, shift registers, graphics controllers, operational amplifiers (op amps), dc-to-dc converters, touch-panel controllers, SRAM, DRAM, and EEPROM. It is also possible for the glass substrate to contain components for signal processing/computation, data storage, and communications.

Recent advances in manufacturing processes are now allowing LCD makers to take the first steps toward attaining the goal of a system LCD. These advances are seen as key to attaining a new generation of electronic mobile devices that are compact, rugged, lightweight, powerful, and energy efficient. In the meantime, these same innovations in manufacturing are making available displays that have high resolution, brilliant color and brightness in any lighting condition, and low power consumption. These new displays are already being designed into today's mobile devices.

A number of LCD manufacturers, including Sanyo, Sharp, Sony, and Toshiba, are con-

ducting R&D activities in search of the best way to combine system components onto a

single LCD glass substrate. These efforts have brought significant innovations to cur-



**Fig. 1:** Sharp's Advanced TFT-LCD module, which has been in production since April 2002, is incorporated in such products as the Sharp GX 10 mobile phone manufactured for Vodaphone.

Sharp

*Joel Pollack is Vice President of the Display Business Unit at Sharp Microelectronics of the Americas, 5700 N.W. Pacific Rim Blvd., Camas, WA 98607-9489; telephone 360/834-8926, fax 360/834-8992, e-mail: joel.pollack@sharpusa.com.*

rent amorphous-silicon (a-Si) processes, have led to the introduction of the low-temperature-polysilicon (LTPS) process, and, most recently, have led Sharp to introduce displays manufactured in a continuous-grain-silicon (CG Silicon) process.

### Amorphous Silicon

Since the introduction of thin-film-transistor LCDs (TFT-LCDs) in 1973 and the subsequent productization of this technology, LCD manufacturing has been accomplished primarily by using an a-Si process. Over the years, advances in a-Si displays have resulted in marked improvements in productivity, color, contrast, viewability, and response rates. Today, these displays are suitable for active-matrix displays in notebook computers, LCD TVs, industrial applications, and portable devices.

A key advance in small sizes has been the development of transmissive displays based on the a-Si manufacturing process. Sharp's Advanced-TFT technology, for example, is a proprietary technology employing reflective-display characteristics for bright outdoor settings while at the same time utilizing transmissive display characteristics in indoor environments (Fig. 1). Unlike other transmissive products, Sharp's Advanced-TFT technology employs differential cell-gap control and color filters optimized for transmissive and reflective characteristics in the corresponding regions of the display pixels. This design avoids the compromises in transmissivity and contrast that are seen in conventional transmissive products. Color rendering remains essentially unchanged whether the display is viewed indoors or outdoors, making these displays well suited for PDAs, mobile phones, and wireless devices.

Despite their versatility, one of the weakest links in today's a-Si TFTs, and where most failures occur, is the tab bond – the attachment of the driver ICs to the TFT bus bars. If the tab could be eliminated, it would be possible to manufacture a product that is more rugged than typical TFTs.

One alternative is chip-on-glass (COG) technology, which is now used for many automotive applications. The COG process connects the LCD controller directly to the LCD glass, without the need for tab-bonding connections, and thereby provides significant ruggedization for these applications. The result is a very compact, thin, and lightweight module. The latest versions of the Palm Pilot

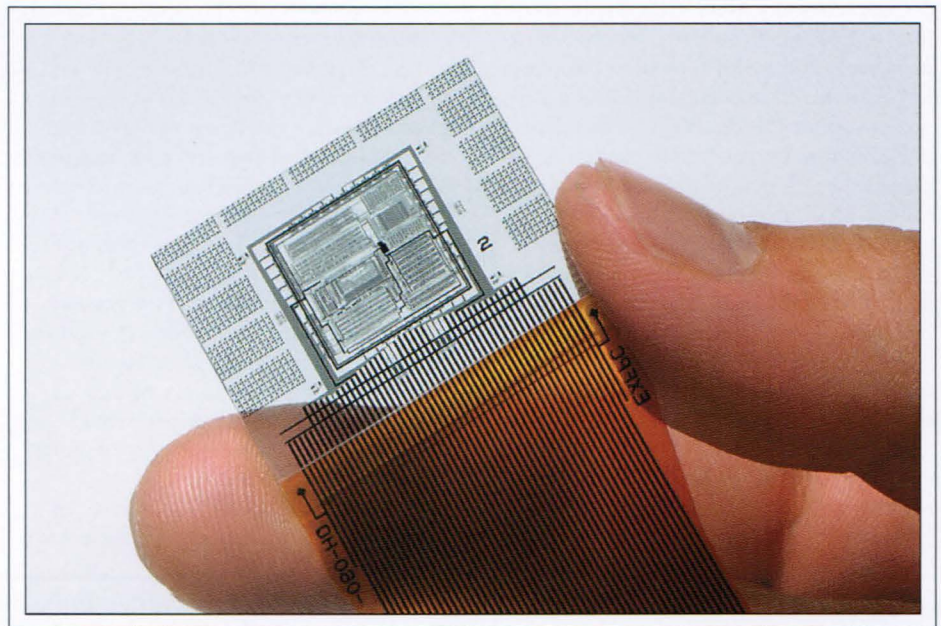

Sharp

**Fig. 2:** In late 2002, Sharp announced the successful integration of its first system LCD, an 8-bit Z80 CPU, onto a glass substrate designed for LCDs. The system uses CG Silicon technology.

utilize COG technology to better enable these units to withstand the shock of being dropped.

Manufacturers can also make field-effect-transistor (FET) arrays of very high density, but there is a limit to the interconnect density, which makes driving these arrays a challenge. The limiting density of the interconnect to a-Si displays has essentially been reached; it is not reliable to use a tab bond or a COG bond above a certain density.

Yet another problem common to a-Si displays relates to the gate delays caused by the select-line resistivity. These lines form resistance-capacitance transmission lines that delay and distort the gate pulses – effects that limit the ultimate size of an active-matrix display. Typically, a-Si TFT fabrication processes have used thin high-resistivity refractory metals which have exacerbated the resistivity problem. To realize larger-area displays, new metallization systems were developed. a-Si also does little to address the issue of external VLSI drive electronics, which are becoming the largest component cost in an LCD system.

### Manufacturing Advances

In order to address these key concerns about a-Si technology, display makers began researching various forms of LTPS processes

for use in LCDs. LTPS technology promised to become an attractive alternative for producing LCDs because it can be used to fabricate driver circuits on the glass substrate at the same time as the pixel-drive FETs. Polysilicon can achieve a quasi-crystalline structure that enables higher electron carrier mobility when it is deposited and annealed at a temperature above 600°C, deposited on a quartz substrate, and fabricated on a metal-oxide-semiconductor (MOS) line. In fact, the best LTPS can attain a carrier mobility that is 200 times that of a-Si. A MOS line permits smaller design rules for the circuits and higher-resolution displays.

The most commonly available LTPS technology, in production the longest, is known as n-channel or NMOS. In the NMOS process, the transistors contain a channel (the region separating the source and drain) that is comprised of an n-type semiconductor. An n-type semiconductor is distinguished by the density of holes in the valence band being exceeded by the density of electrons in the conduction band. In n-type semiconductors, electrons are the majority carriers and holes are the minority carriers. This n-type behavior is induced by the addition of donor impurities, such as arsenic or phosphorus, to the crystal structure of silicon.

## system-on-LCD

Complementary MOS (CMOS), the second form of LTPS, uses both an n-channel and a p-channel. In the CMOS process, the transistors contain a channel that is made of a p-type semiconductor, distinguished by the density of electrons in the conduction band being exceeded by the density of holes in the valence band. In p-type semiconductors, holes are the majority carriers and electrons are the minority carriers. This p-type behavior is induced by the addition of acceptor impurities, such as boron, to the crystal structure of silicon. The combination of both n- and p-channel processes produces a push-pull effect, enabling higher electron carrier mobility than a simple n-channel process. However, this combination also requires more masking steps and is far more complex to manufacture.

Although the NMOS process requires only a limited number of layers, it brings with it a number of limitations. Circuitry built with an NMOS process has limitations in operating speed that limit these designs to QVGA-or-smaller displays. The power consumption of NMOS circuits is higher than more recent CMOS processes. The area necessary for an NMOS circuit is typically larger than that for an equivalent CMOS circuit, so NMOS technology is not compatible with the typical requirements of mobile products (low power consumption and small bezel area). In addition, for a given power-supply voltage, an NMOS-based circuit will respond slower than a CMOS-based circuit, leading to the limitation of quarter-VGA LCDs.

Although some benefits can be attained using LTPS, manufacturers must overcome a

number of challenges. First and foremost, all processing must be conducted at a thermal budget compatible with low-cost standard glass, *i.e.*, the glass can not become so hot that it softens and loses its mechanical stability. In addition, equipment for the additional processes must be introduced and optimized to perform such tasks as reduced H-content silicon deposition, crystallization, ion-doping, gate dielectric film formation, and hydrogenation.

### Continuous-Grain Silicon

As a result of searching for solutions to these problems, Sharp Corp. recently introduced a new technology called continuous-grain silicon (CG Silicon), a patented technology developed jointly by Sharp and Semiconductor Energy Laboratory Co., Ltd. Unlike a-Si

**Table 1: Comparative Performance of Low-Temperature-Polysilicon, Amorphous-Silicon, and Continuous-Grain-Silicon Displays**

#### 3.7- and 4.0-in. Continuous-Grain-Silicon Panels

	CG Silicon Display	CG Silicon Display	LTPS Display	a-Si Display
	LQ037V7Dxx	LQ040V7Dxx	4.0-in. LPS	LQ035Q7DB02
Display type	Transflective	Transflective	Transmissive	Transflective
Display active area (mm × mm)	56.16 × 74.88	60.48 × 80.64	80.64 × 60.48	53.64 × 71.52
Display diagonal (in.)	3.7	4.0	4.0	3.5
Number of pixels	480 × RGB × 640	480 × RGB × 640	640 × RGB × 480	240 × RGB × 320
Dot pitch/pixels per inch (mm/ppi)	0.039 × 0.117 / 217	0.042 × 0.126 / 202	0.042 × 0.126 / 202	0.0745 × 0.2235 / 113
Outline (mm × mm × mm)	65 × 89.8 × 4.2	69.3 × 96 × 4.2	94.04 × 69.98	65 × 85 × 4.5
Luminance (cd/m <sup>2</sup> )	60	60	30	50
Multi-resolution/colors 18 bit ⇔ 3-bit digital RGB	VGA / 260k QVGA / 260k QVGA / 8 color	VGA / 260k QVGA / 260k QVGA / 8 color	VGA / 260k	QVGA / 260k only
Drivers	Source driver/discrete Gate driver/monolithic	Source driver/discrete Gate driver/monolithic	Source driver/discrete Gate driver/monolithic	Source driver/discrete Gate driver/discrete
Functions	Multi-resolution Partial display operation Mirror-image scanning; x and y directions	Multi-resolution Partial display operation Mirror-image scanning x and y directions	VGA only	QVGA only
Input signal	6-bit digital	6-bit digital	6-bit digital	6-bit digital
Power consumption (mW)	VGA: 77* QVGA: 25	VGA: 77* QVGA: 25	VGA: 380	QVGA: 35*

\*Not including backlight power consumption.



and poly-Si, CG Silicon aligns its silicon grains with continuous atomic-level continuity at the grain boundaries. This continuity permits electrons to travel across the semiconductor at a carrier mobility of 300 cm<sup>2</sup>/V-sec, which is approximately 600 times faster than that of a-Si and approximately three times faster than the best LTPS. This enhanced electron mobility, which comes far closer to that of single-crystal silicon (600 cm<sup>2</sup>/V-sec), opens the door to building CPUs, memory drivers, digital/analog converters, and other peripherals onto the same substrate as the display.

Although Sharp has developed displays using LTPS, it has now committed its manufacturing resources to the new CG Silicon process because CG Silicon enables the manufacture of highly integrated panel circuitry and substrates in a low-temperature process. The CG Silicon manufacturing process also has the same number of layers as an n-channel process, which makes it simple and efficient, with high yields.

The key to CG Silicon technology is the crystallization step that yields the high-quality active layer which is used to build the TFTs. Starting with a display-grade glass (such as

Corning 1737 alumina silicate glass), a layer stack is deposited, consisting of basecoat film and a-Si film. A metal catalyst is introduced into the a-Si film, which is then subjected to crystallization in order to nucleate and grow high-quality crystal domains in the film. Typically, a combination of solid-phase crystallization and laser annealing is used to achieve the high-crystal-quality poly-Si film.

TFTs are then built using a CMOS fabrication flow that involves simultaneous fabrication of pixel and driver transistors on the glass substrate. This fabrication flow is now compatible with display-grade glass substrates because the maximum process temperature does not exceed 600°C.

CG Silicon, being relatively easier to manufacture and producing even better viewing characteristics than LTPS, is a technology that will enable the creation of a system LCD. For example, handheld devices typically require special graphics controllers and a multiplex controller. The goal, instead of using two separate chips on the motherboard, is to eventually integrate these functions and control electronics into the CG Silicon panel. By integrating the many system functions into the

single panel, the total system cost can be reduced, and system reliability and image definition can be increased (Fig. 2).

A key feature of the system-LCD architecture is the ability to dynamically control the resolution and color depth of the display according to the data to be displayed. Because the drivers are not discrete elements, there is nothing to deter the manufacturer from placing VGA drivers on one end of the display's column bus bars and QVGA drivers on the opposite end.

This proprietary Multi-Driver technology enables Sharp to develop displays that can operate in three principal modes: full-color VGA, full-color QVGA with 65,536 colors, and monochrome QVGA. These high-transmissivity LCDs are designed with reflective electrodes in the pixel regions that do not transmit light. The electrodes further boost screen brightness by reflecting ambient light, which provides significantly better viewability in outdoor settings under bright, sunny conditions.

One other feature that can be incorporated into the display is ultra-low power consumption, which allows the average power con-

**Table 1: Comparative Performance of Low-Temperature-Polysilicon, Amorphous-Silicon, and Continuous-Grain-Silicon Displays (continued)**

**7.1- and 7.4-in. Continuous-Grain-Silicon Panels**

	<b>CG Silicon Display</b>	<b>CG Silicon Display</b>	<b>LTPS Display</b>	<b>a-Si Display</b>
	LS071X7LA01	LS074KLxx	6.3-in. LPS	LQ065Y5DG01
LCD type	Highly transmissive advanced; sunlight readable	Highly transmissive advanced; sunlight readable	Transmissive Not sunlight readable	Transmissive Not sunlight readable
Display active area (mm × mm)	144 × 108	161 × 96.8	129 × 96.8	130.4 × 78.24
Display diagonal (in.)	7.1	7.4	6.3	6.5
Number of pixels	1024 × RGB × 768	1280 × RGB × 768	480 × RGB × 640	800 × RGB × 480
Dot pitch (mm) / ppi	0.047 × 0.141 / 180	0.042 × 0.126 / 202	0.042 × 0.126 / 202	0.06 × 0.163 / 156
Outline (mm)	169 × 122 × 3.6–6.8	183.4 × 116.2 × 3.5–6.5	151.9 × 115.8 × 7.3	157.2 × 89.7 × 8.4
Luminance (cd/m <sup>2</sup> )	180	180	150	350
Colors	260k	260k	260k	260k
Drivers	Source driver/discrete Gate driver/monolithic	Source driver/discrete Gate driver/monolithic	Source driver/discrete Gate driver/monolithic	Source driver/discrete Gate driver/discrete
Input signals	6-bit digital	6-bit digital	6-bit digital	6-bit digital
Power consumption (W)	< 3.2	< 3.4	3.2	4

## system-on-LCD

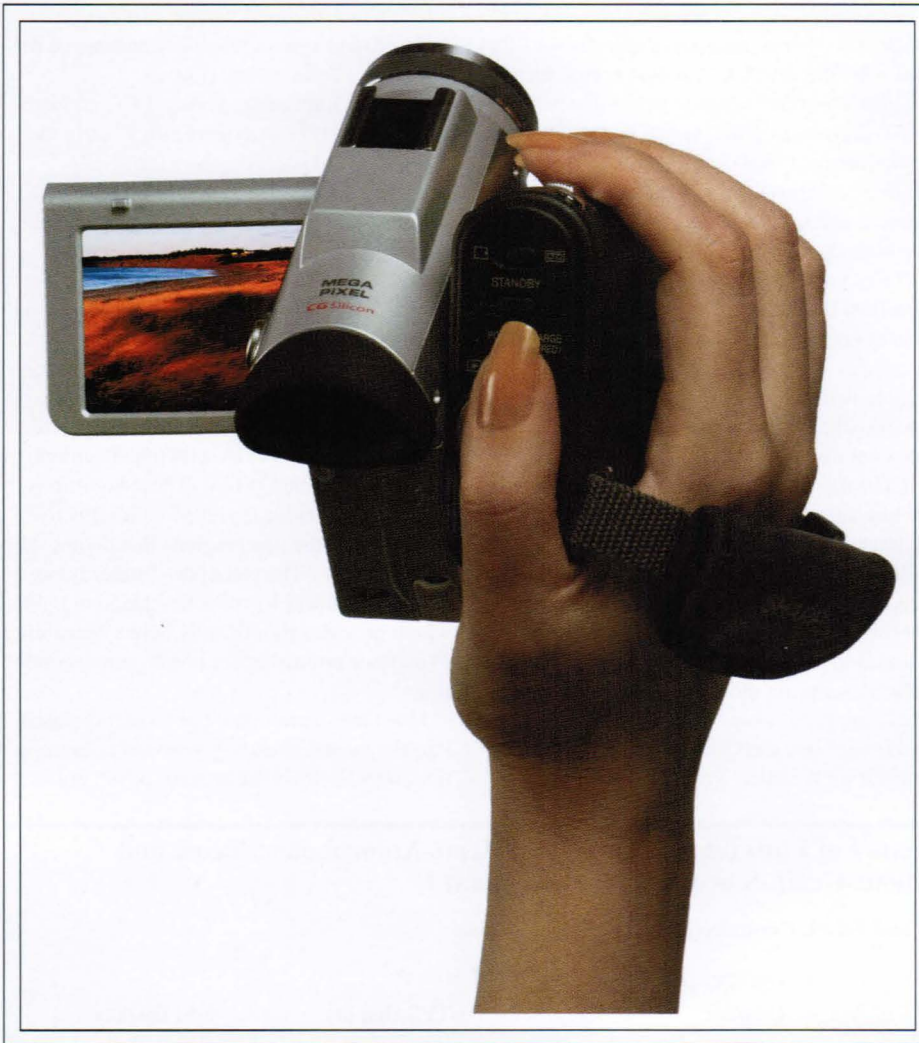

**Fig. 3:** Among the first products that incorporate the system-LCD architecture are Sharp digital Viewcam camcorder models VL-Z1U, VL-Z3U, VL-Z5U, and VL-Z7U, which are equipped with 2.5-in. color CGS screens.

sumption of the display to be reduced while still allowing the display to deliver high performance when required. This feature allows the display to be operated in a status mode, a simple graphics mode, and full-video mode, each at different power levels. The power consumption of Sharp's 3.7-in. display, for example, is only 14 mW for VGA/full-color for graphics, 8 mW for QVGA/full-color, and 2 mW for QVGA/monochrome in a status mode (Table 1).

CG Silicon technology is driving the development of a new generation of smaller, thinner, more versatile, more powerful, and more energy-efficient mobile devices. The first CG

Silicon product demonstration was a 2.6-in. monochrome high-temperature panel with a resolution of 1280 × 1024 pixels. After further refinement, Sharp demonstrated the first prototypes of a low-temperature CG Silicon process in January 2001, heralding the creation of larger LCD panels using glass substrates. At the same time, the company announced it was investing approximately \$427 million to convert its "NF1" line in Tenri, Japan, from manufacturing a-Si displays to manufacturing the first commercial CG-Silicon-based TFT displays. The first products that incorporate the system-LCD architecture include Sharp's Zaurus SL-C700

that is available in Japan, along with four digital Viewcam camcorders equipped with 2.5-in. color CG Silicon screens (Fig. 3).

Sharp anticipates that further evolution of CG Silicon – to an electron mobility of over 500 cm<sup>2</sup>/V-sec – will permit the integration of high-speed circuits onto the TFT substrate. This will bring closer the ultimate goal of a complete system-on-panel that makes possible paper-thin multimedia laptops and powerful, multi-function credit-card-sized devices.

### The Potential of CG Silicon

When combined with technologies such as reflective color TFT-LCD and Advanced TFT-LCD, which provides high viewability in both bright and dark environments, CG Silicon allows OEMs and developers to differentiate themselves from competitors and enables the production of LCDs with high added value. Developers still have a long way to go before they extract all the performance gains possible from CG Silicon.

Initially, new CG Silicon components will take the form of op amps and graphics controllers, but the technology will also support touch-panel controllers and perhaps, someday, the entire microcontroller (MCU) on the panel. The ability to expand on these concepts is limited only by the imagination.

More research is certainly warranted in the area of LCD technologies, but Sharp's research suggests that CG Silicon holds great potential for allowing engineers to integrate components such as the LCD driver circuitry and the controller ICs on the same glass substrate as the LCD panel while simultaneously delivering a better user experience to consumers. ■

# SID '04

Symposium, Seminar,  
and Exhibition  
Seattle, Washington  
Washington State  
Convention and Trade Center  
May 23–28, 2004

# Designing Touch LCDs for Portable Devices

*The enhanced functionality of portable devices has outpaced the user's ability to view information, execute commands, and easily navigate through complicated menus. The solution is the integration of touch technology with a highly visible display.*

by Bruce DeVisser

**P**ORTABLE electronic devices have made revolutionary changes in our daily lives. From mobile telephones to personal digital assistants (PDAs), these battery-powered marvels perform a wide range of useful applications. While telephones can get by with a numeric keypad and a few extra buttons, PDAs and related devices must convey more information and provide a more versatile control system. As a result, most rely on a liquid-crystal-display (LCD) screen with a touch panel to provide an intuitive, graphical man-machine interface (MMI) commonly called a graphical user interface (GUI).

The trend to incorporate a touch GUI has expanded to encompass products that previously did not use an LCD and those that had LCDs but no touch interface. Examples include medical monitors, electronic control systems, and various instrumentation applications.

Typically, a popular point at which to introduce a GUI is at the inception of a new design. The evolution of a product design to a new model and the updating of a current design are also good points to consider adding the touch-GUI component. Regardless of the

product stage, the design team will face many technology choices. But independent of technology, the optical-design goals of the product must remain the paramount concern.

## Design for Touch

Original-equipment manufacturers (OEMs) continually strive to satisfy user demand for additional features, enhanced functionality, and ease of use. For most users, "ease of use" relates directly to the quality of the user interface. Since the primary user interface in the portable market segment is the touch display, marketers define a highly visible display as a key element. This translates into an engineer-

ing design requirement, and achieving it becomes one of the main project goals, especially considering that the LCD is often a top-cost item.

Designers select the LCD primarily based on modes of use, battery-life requirements, competitive goals relative to display appearance and performance, and – most certainly – cost. After the designers complete the lengthy and involved process of choosing the display, they must then select a touch panel. For many engineering-team members, this is a new experience and therefore a learning opportunity; for some others, it is an iteration in the process of life as a product-design engineer;

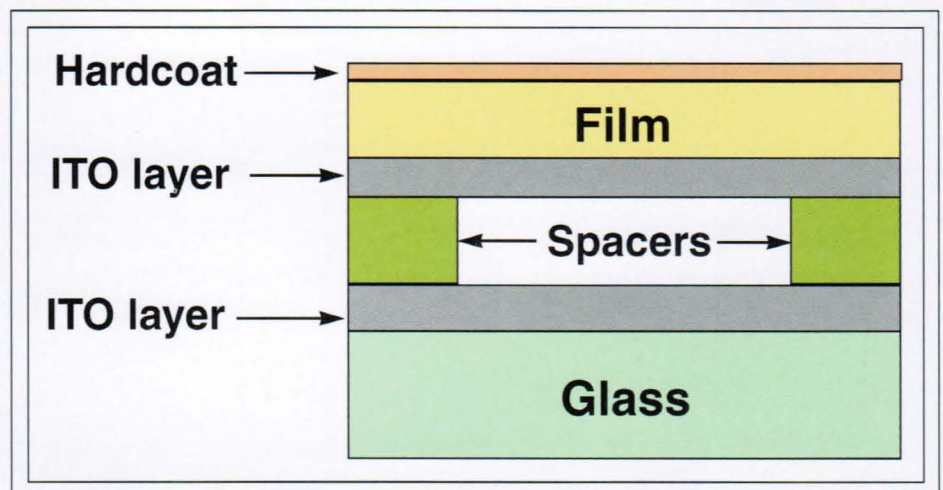

**Fig. 1:** The resistive touch panel is the most popular for portable applications. Its basic construction consists of a glass panel, an ITO resistive coating applied to the glass, spacer dots, an ITO resistive coating applied to the film, a flexible plastic film, and a hardcoat applied to the film.

**Bruce DeVisser** is Product Marketing Manager for Touch Input Devices at Fujitsu Components America, Inc., 250 E. Caribbean Dr., Sunnyvale, CA 94089; telephone 408/745-4928, fax 408/745-4971, e-mail: bdevisser@fcai.fujitsu.com. He has more than 20 years experience in man-machine interface analysis, design, and implementation.

and a small but growing group realize this will be an extension of the LCD criteria.

The growth of the portable-device market – as with any new or expanding product area – creates new design opportunities that engineers might not yet have experienced. This is one of the positive benefits of involvement in product design; the constantly changing set of challenges offers continuing opportunities to learn something new.

### Application Requirements

Presenting adequately viewable information on a portable device's display can be a significant challenge. High-ambient-light levels – from fluorescent or incandescent fixtures, sunlight coming through the window, reflected light from windows, or a combination of sources – can make it difficult or impossible to read a display. Whether the display is color or monochrome, marketplace acceptance depends heavily on the user's ability to see the information on the screen.

LCD brightness levels can be increased through back and front lighting and other enhancements to achieve the desired readability. But when a touch panel is added to the LCD, the resulting optical stack can produce various effects, some of which may be interesting, but none are desirable. These typically include reduced light transmission, ambient and spot-lighting reflections, and distracting patterns produced by optical interference between the various layers.

The solution to these problems consist of choosing appropriate basic touch-panel components and adding various optical treatments that can provide significant improvement. Although any additional materials or processes inherently add cost – sometimes substantial cost – this must be weighed against the cost of product failure. The goal must be a product that performs to the designer's requirements at a reasonable cost. Fortunately, designers can often achieve this without resorting to expensive methods.

### Picking Parameters

The most popular type of touch panel for portable applications is the film-on-glass analog resistive panel. Resistive touch panels (RTPs) offer several choices of product properties, such as pen-and-finger or pen-only operation, tail length and position, and actuation force. For this discussion, we will focus on the choices that affect optical performance.



Apollo Display Technology and Optrex America

**Fig. 2:** The clear resistive touch panel from Fujitsu has 86% light transmission and minimal effect on the color and clarity of the Optrex 6.4-in. TFT-LCD located behind it.

The RTP's basic bottom-to-top-layer construction consists of a glass panel, an ITO resistive coating applied to the glass, spacer dots, an ITO resistive coating applied to the film, a flexible plastic film – usually polyethylene terephthalate (PET) – and a hardcoat applied to the film (Fig. 1). For many of these items, there are commonly available choices.

- **Glass type:** Normal (soda) glass or chemically strengthened (CS) glass.
- **Glass thickness:** Typically 0.7 or 1.1 mm for portable applications, although the available range extends from 0.55 to 1.8 mm.
- **ITO:** A variety of color effects are available.
- **Hardcoat:** Clear or anti-glare (AG) surface.

The optical transmissivity (or "transparency") of the resulting combinations typically falls in the range of 78–82%, although higher values are available.

The glass choices are relatively simple: Thinner is better for weight and optical requirements as long as strength goals are met. Glass strength, however, is an area that is often not defined because it is difficult to

accurately characterize the user environment, and glass strength ends up being evaluated empirically through user trials. Typically, LCD sizes under 4 in. use 0.7-mm glass, and other portable applications use 1.1-mm glass.

The ITO choices are not often a concern because vendor samples can be used to determine if there is any undesired coloration from the chosen product range. In the case where a specific color change is desired, it is very helpful to provide a working LCD sample to the RTP vendor. This will help the vendor select the most appropriate ITO coating to meet color goals for the specific LCD–RTP assembly.

The hardcoat is the protective finish applied to the exterior of the plastic-film layer, and there are two basic types: clear and anti-glare (AG). Clear hardcoat has a minimum effect on the LCD image, although there is always some measurable effect from any additional optical layer. Clear hardcoat has the disadvantage of first-surface glare, and it is scratched more easily than AG hardcoat. Clear hardcoat is the most prevalent choice for reflective applications because it does not scatter or diffuse the light. It is also becoming

## touch-LCD design

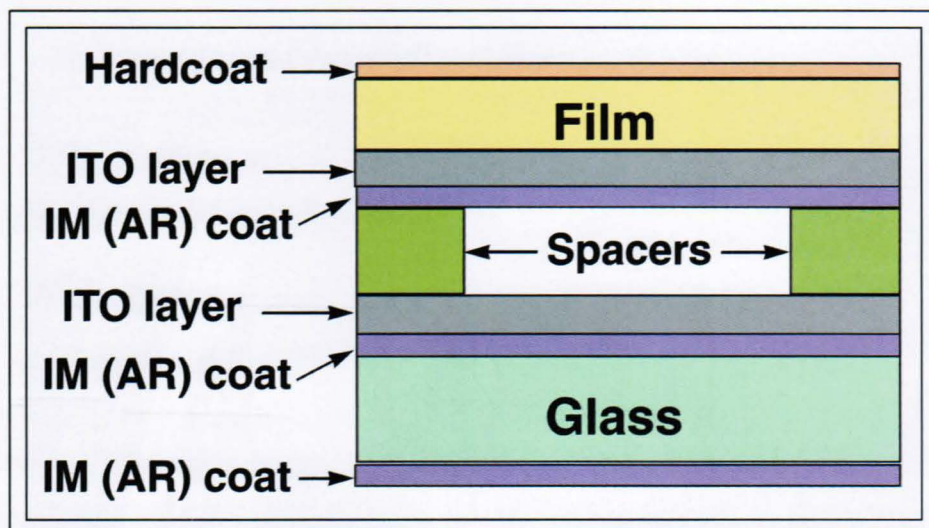

**Fig. 3:** Index-matching (or anti-reflection) coatings applied to the touch panel's surfaces significantly reduce internal light reflections within a resistive touch panel, resulting in improved visibility of the LCD surface and transmissivity of up to 92%.

popular for transfective- and some transmissive-LCD uses.

AG hardcoat is used to reduce first-surface reflections, commonly termed glare. It is also referred to as "white shirt" or "mirror effect." Optically, AG hardcoat scatters part of the light reflecting off the surface. The image on the LCD is also diffused, unfortunately, which the viewer perceives as reduced contrast. This effect increases significantly as the distance between the LCD surface and the RTP increases.

AG hardcoat also results in a reduced viewing angle, although this is apparent mainly at extreme viewing angles and is not a concern in most cases. AG hardcoat also provides the best resistance to scratching, which is an important consideration if a stylus is used as the primary input device. Finally, AG hardcoat can be effectively treated to embody anti-smudge (AS) properties. This can be valuable where oily fingerprints could build up and interfere with LCD visibility, as with automotive diagnostic tools.

### Determining the Optimum Solution

Choosing the best design solution requires a consideration of several factors, so a well-defined specifications or requirements list will aid engineers immensely in making choices. Even those items not easily measured, such as "good user display readability outdoors," are valuable criteria. No matter how much defini-

tion is provided, adequate time should be spent testing and reviewing samples with other decision-makers in the organization. No matter how well a product meets its specifications, if it does not satisfy user requirements, the design is not finished.

A good starting point is to determine upfront whether a clear or AG hardcoat is required. This will save time because other more advanced choices depend upon this. A basic rule is that if reflections can realistically be avoided by positioning the device, then a clear hardcoat is the primary choice (Fig. 2). It also provides better viewing clarity than AG hardcoat for the same transmissivity value because the light is neither scattered or diffused.

However, a reflection that blanks out part of the display screen will frustrate the user; and when the AG hardcoat is required, a higher-transmissivity LCD is necessary to improve user viewing. Transmissivity is the measure of how much of the LCD's light – both reflected and transmitted – reaches the user through the touch panel. A transmissivity of 80% generally means that an LCD with a 100-nit output will measure 80 nits at the user's viewing point. Typical AG values range from 5 to 10%, but lower values are also available, providing the opportunity to adjust the solution to the application.

Often, there is no perfect solution. One of the factors will emerge as the controlling ele-

ment, and subordinated design parameters will have to be arrived at through compromise.

### Under the Sun

Many portable electronic devices are used outdoors at least part of the time, so sunlight readability can be a major concern. Power budgets are typically very limited, so reflective and transfective LCDs are used almost exclusively, as are clear RTPs.

Recent developments in RTP materials have improved transmissivity beyond 90%, with 93% achieved in production. These gains were made possible through index matching (IM), also called anti-reflection (AR) technology.

Applying IM coatings to RTP surfaces significantly reduces internal reflections and results in improved visibility of the LCD surface (Fig. 3). The first-surface reflection from the RTP must still be minimized through positioning, but the overall improvement in usability can be quite impressive.

A few portable devices are designed for direct-sunlight readability, even if for a limited amount of time. These devices can utilize a strong backlight to achieve the high-lumen output required for sunlight readability, and therefore can use a circularly polarized (CP) RTP for optimum performance. The structure of the CP filter eliminates most external light reflection, has an AG hardcoat, and allows nearly 80% of the transmissive-mode LCD light to pass through, resulting in a clear display regardless of sun position.

### Other Directions

The future promises further advances in materials and even higher performance. Weight and cost are always primary factors for portable devices, and emerging technologies may help designers create products that are lighter and less expensive.

Plastic technology has been in use for a relatively short period of time – although it can be found in several applications – so it has not yet developed enough to fulfill expectations. The plastic needs better transmissivity and durability, which will require more materials development.

One of the alternative plastic solutions is the film-on-film touch panel, which eliminates the relatively thick, plastic, back-panel support sheet. The LCD surface glass is used for support instead. Normally, this would be unacceptable because the touch pressure



Fujitsu Laboratories

*Fig. 4: Fujitsu Laboratories has recently developed miniaturized SAW technology for the portable-device market. The technology was previously suitable only for stationary large-screen applications.*

would alter the liquid-crystal layer thickness, which would change the image. LCDs can be made with an internal structure to prevent this deformation, which makes LCD glass support practical.

Also under development is surface-acoustic-wave (SAW) technology for portable devices. Previously only suited to stationary large-screen applications and comparatively quite expensive, Fujitsu Laboratories has announced the development of a miniaturized SAW-technology touch panel targeting the portable-device market (Fig. 4).

The portable-electronic-device market is changing rapidly as some products merge their functions (mobile telephones and PDAs) and new categories appear (electronic books).

One fact remains certain: Touch input will remain a key factor in the user interface of these devices, especially as their displays become more sophisticated. Advances in touch-input technology are providing designers with a growing range of choices. As a result, we can expect to see smaller and lighter devices that work longer on better batteries and are also easier to view and use. We can expect end users to reward these improved designs by making them successful in the marketplace. ■



**CyberTouch** designs and manufactures specialty touch screens for the medical, industrial, military and aerospace industries.



Select from a wide range of off-the-shelf touch screens or have us custom design one for you.

Get in touch with CyberTouch!



**CyberTouch**

805.499.5000 • 800.958.4321  
cybertouch.com

# A View-Navigation System for Hand-Held Portable Displays

*RotoView™ scrolling technology makes large virtual images accessible to small hand-held devices such as PDAs and mobile telephones.*

by David Y. Feinstein

**T**HERE have been major advances in screen display technology for portable products over the past decade. Higher resolution, improved color quality and backlighting, lower power consumption, and better wide-angle viewing have resulted in vastly improved products for the end user. These developments have been important contributions to the emergence of smart hand-held devices with increasing levels of sophistication. But one challenge remains: viewing large images, such as Web pages, maps, and spreadsheets, on a small hand-held display.

Users want access to ever more complex information on devices that remain small and portable. Trying to achieve these mutually incompatible goals by further increasing pixel density necessitates the use of cumbersome optical magnification. Until recently, the only way to view complex graphical information on a small screen has been to sequentially view selected small areas of a stored virtual image. This inconvenient approach has led to the development of RotoView™ scrolling technology which offers users a view-navigation system that is both intuitive and easily controlled by one hand.

*David Y. Feinstein is Founder and President of INNOVENTIONS, Inc., 10425 Bissonnet St., Houston, TX 77099; telephone 281/879-6226, fax 281/879-6415, e-mail: david@innoventions.com, URL: www.rotoview.com.*

Early hand-held devices achieved view navigation with an up/down button and an operating system (OS) that offered a very limited number of icons. More recent hand-held devices have employed a flat joystick for scrolling, but devices with scrolling switches often require two-handed operation. Even when the buttons are eliminated in futuristic voice-recognition hand-held devices, there is the problem of continually issuing voice commands. Imagine saying, "left, up, down, ..." to your PDA. (Picture 400 passengers on an airplane all saying this together.)

## Tilt!

The INNOVENTIONS, Inc., RotoView™ view-navigation software allows the small display of a hand-held device to scroll through large virtual images in response to changes in the device's orientation. The user simply tilts the device in the desired direction.

RotoView can be visualized as a small window placed in front of a document larger than the window. To see beyond the window's boundaries, the viewer naturally wants to tilt the window sideways relative to the document to take a peek at more information. When the



**Fig. 1:** Tilting a device equipped with RotoView™ scrolling technology navigates the display "window" across the image bitmap in the direction of the tilt.

user tilts the device away to get this "peek," RotoView moves the display window "across the document" in the direction of tilt.

Modern tilt sensors enable RotoView to achieve a quick response to the user's orientation changes. The use of dynamically changing response curves to process the sensor's data eliminates the need to rely on more accurate and expensive sensors. A user controls the view navigation by means of continuously adjusted hand movements which tilt the display in the desired direction (Fig. 1). This creates a closed control loop that alleviates the need for an exact linear relationship between the orientation changes and the resulting display navigation.

### Choosing the Right Sensors

Orientation sensors have been used for many years in virtual-reality systems and in a variety of three-dimensional pointers and 3-D mice. They include microelectromechanical-system (MEMS) accelerometers and gyroscopes, magnetic sensors that detect angular changes relative to the Earth's magnetic flux, and traditional floatation devices that measure tilts by the movement of a floating medium, similar to the action of a ball in a liquid. The floatation devices are generally too slow and bulky, and the modern magnetic sensors based on magneto-resistive elements require a complex set/reset circuitry to keep the sensors in a high-sensitivity state.

MEMS technology integrates mechanical sensors and electronics on a common silicon substrate. The mechanical sensors are formed by etching away silicon or by adding structural layers. The MEMS accelerometer is based on a micromachined polysilicon form that is suspended elastically above the base wafer. The suspended structure moves in response to forces arising from the acceleration of gravity. The device generates a signal related to the acceleration by measuring the differential capacitance between the base wafer and the suspended structure.

The accelerometer can provide a measure of "static" tilt angle relative to the horizon by using the following function:  $\text{tilt angle} = \arcsin(A/g)$ , where  $A$  is the measured acceleration and  $g$  is Earth's gravitational acceleration. This function indicates that the sensor achieves high sensitivity when the measuring axis is parallel to the Earth's surface and low sensitivity when the measuring axis points toward the Earth's center

(but there are ways of dealing with this limitation).

At INNOVENTIONS, Inc., we like the MEMS accelerometers for the RotoView application because of their extremely low current – less than 0.4 mA – and low operational voltage of 3 V, acceptable tilt resolution, adequate response time, ease of interfacing, small size, and low cost. Analog Devices, Inc., has recently announced the ADXL311 MEMS dual-axis accelerometer that is priced at \$2.50 in volume quantities and comes in a  $5 \times 5 \times 2$ -mm LCC package.

Miniature mechanical gyroscopes detect angular changes arising from the gyroscopic effect that causes the axis of a rotating mass to move in a direction perpendicular to the original angular change. These gyroscopes are too bulky and power hungry to be used in hand-

held devices, but MEMS technology has come to the rescue with the recent introduction of gyroscopes that employ electrostatic fields that vibrate a polysilicon sensing structure into its resonant state. When the orientation of the device changes, the vibrating structure produces a Coriolis force that is measured through changes in capacitance.

The MEMS gyroscopes come in single-axis packages that are twice the size of the MEMS accelerometers and consume about 8 mA. Their added complexity, which arises partly from the need to generate 16 V internally for the electrostatic fields, results in a cost that is currently 5–10 times that of the MEMS accelerometers. Unlike the accelerometers, MEMS gyroscopes have the advantage of consistent sensitivity at any angle and they do not depend on gravity.

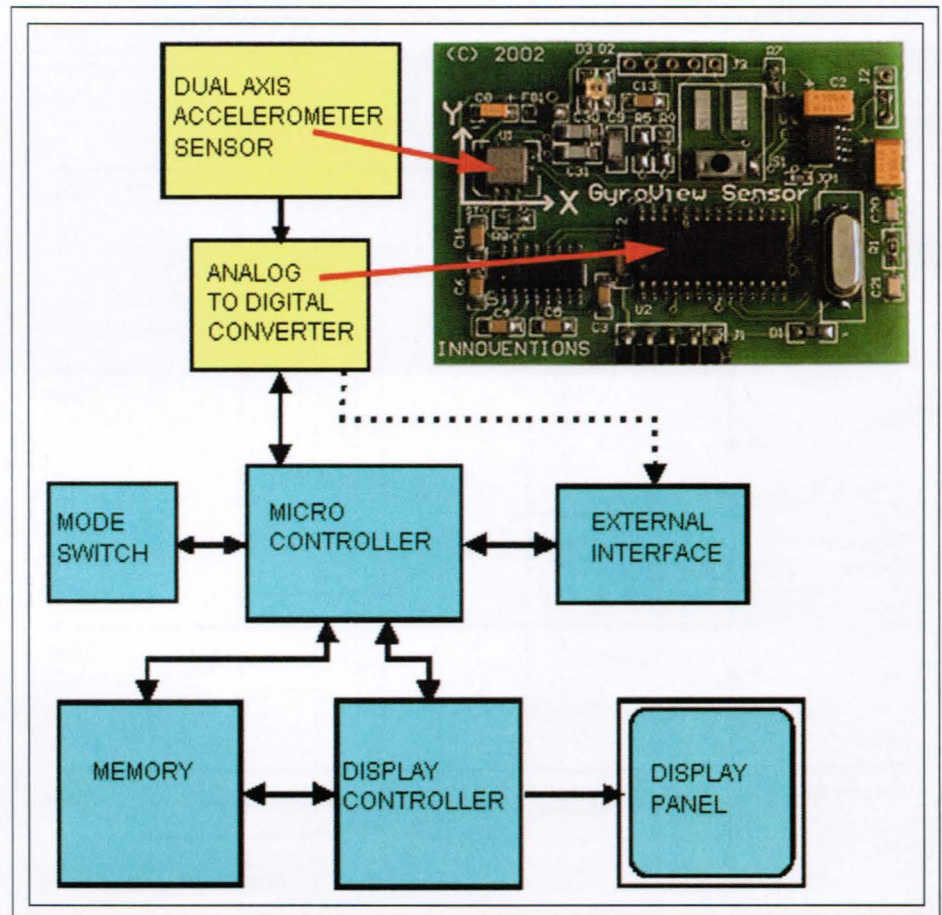

Fig. 2: Shown are a block diagram and photograph of the RotoView™ sensor module. Ideally, RotoView should be implemented at the core electronics and operating-systems level (solid lines). If implemented as an add-on module, the sensor interface would connect to the handheld device's external interface (dotted line).



## case study

Optical gyroscopes send laser light around a fiber-optic ring in both directions. Changes in the interference pattern of the two waves are used to detect rotational movements around the ring through the Sagnac effect. Although currently too expensive for a hand-held application, optical gyroscopes may become affordable within the next 10 years.

### System Design

The core electronics of a smart hand-held device employs at least one microcontroller, a display controller, and memory storage for program and display data (Fig. 2). These functions are often integrated into a single chip or a processor-and-chipset arrangement. (For clarity, other common components, such as the power source and the keyboard/stylus interface, are not shown in the block diagram.) The mode switch selects between fixed mode and view-navigation mode and

can be controlled by a button or by using the software to detect specific hand gestures.

RotoView relies on a dual-axis MEMS accelerometer to detect changes in the spatial orientation at which the device is held. The sensor is mounted so that its x- and y-axes generally coincide with the "pitch" and "roll" axes of the device (an optional z-axis sensor may be used to improve performance). The sensor provides analog voltages or duty-cycle modulation (DCM) signals that are responsive to the tilt of the sensor and hand accelerations along each axis. The sensor interface converts these analog signals to digital format.

In the view-navigation mode, the microcontroller translates the changes in pitch and roll orientation to navigation commands that scroll the large virtual image stored in the memory. This process is controlled by the dynamically changing response curves of the RotoView navigation algorithm.

The user's hand movements are too complex to be described as mere changes in tilt angle; all hand movements include some lateral movements, which produce acceleration components that add to the sensor's output. But as it turns out, this is not a problem. The desired dynamic response curves can be achieved with a well-chosen non-linear dynamic algorithm in conjunction with the natural (and subliminal) closed loop comprising the user's hand movements and the resulting navigation of the display. The loop accommodates both the lateral movements and the actual tilts.

Ideally, RotoView should be implemented in the core electronics and operating-systems level (as indicated by the solid line in Fig. 2), with the sensor interface connecting directly with the microcontroller or chipset *via* two A/D channels. If implemented as an add-on module, the sensor interface would connect to the hand-held device's external interface using RS232, USB, or other standard protocol (dotted line).

### Changing the Response Curves

The stored response curves that relate the measured changes in device orientation to the amount of image area to be navigated must be carefully designed because they are critical in achieving user-friendly navigation. We have found that the best performance is achieved when the response curve is changed dynamically both in time and magnitude.

One of the disadvantages of a fixed response curve is that the user must perform very small orientation changes when trying to achieve fine navigation. This task may be too delicate for most users. Dynamically changing response curves enable the view-navigation session to start with a large, coarse correlation (Fig. 3). In such a design, the user quickly gets the display to the general area of interest at the start of the navigation session. As the session continues, the correlation values become smaller, so that the user can continue to make relatively coarse and easy hand movements and still be able to slowly navigate to the final view. The graph illustrates how a relatively large orientation change during fine navigation (after  $t_3$ ) only slightly reverses the direction of the navigation, while smaller changes during coarse navigation ( $t_1 - t_2$ ) have much larger effects.

Such dynamic response curves also enable the use of less refined (and therefore cheaper) sensors. Even if the sensor exhibits abnormal

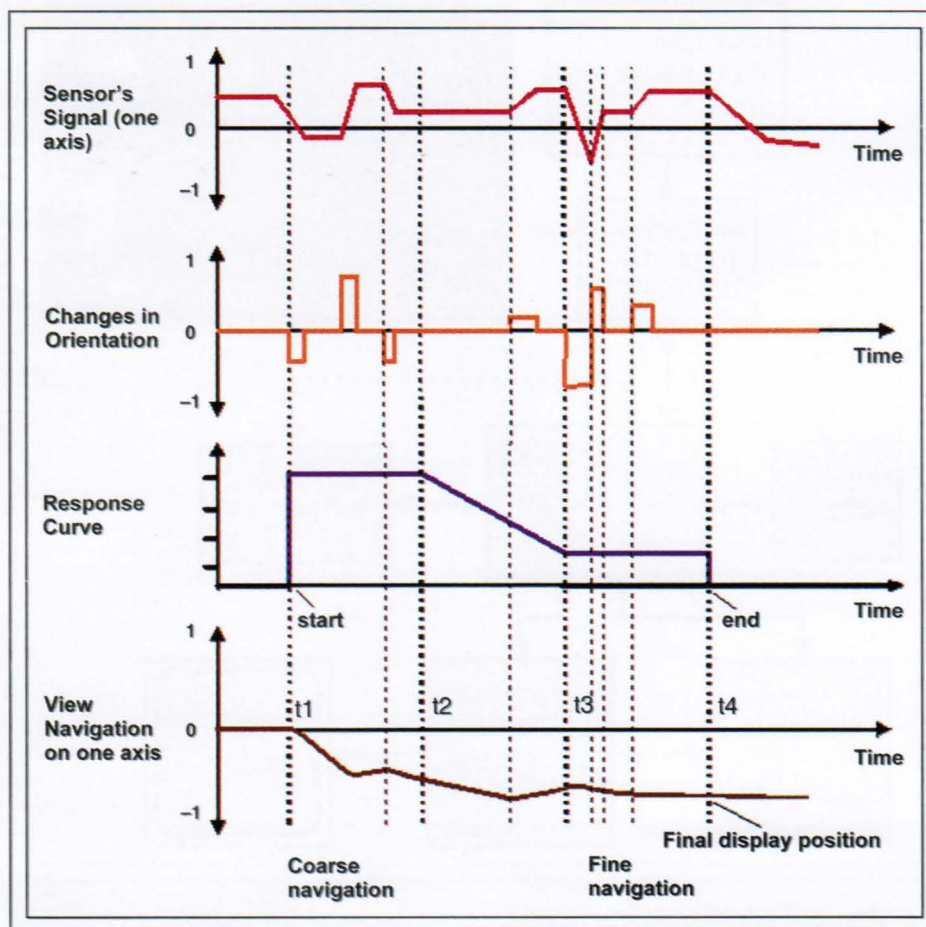

Fig. 3: During the view-navigation session, a dynamic response curve automatically changes the correlation between the sensor's signals and view navigation from coarse to fine.

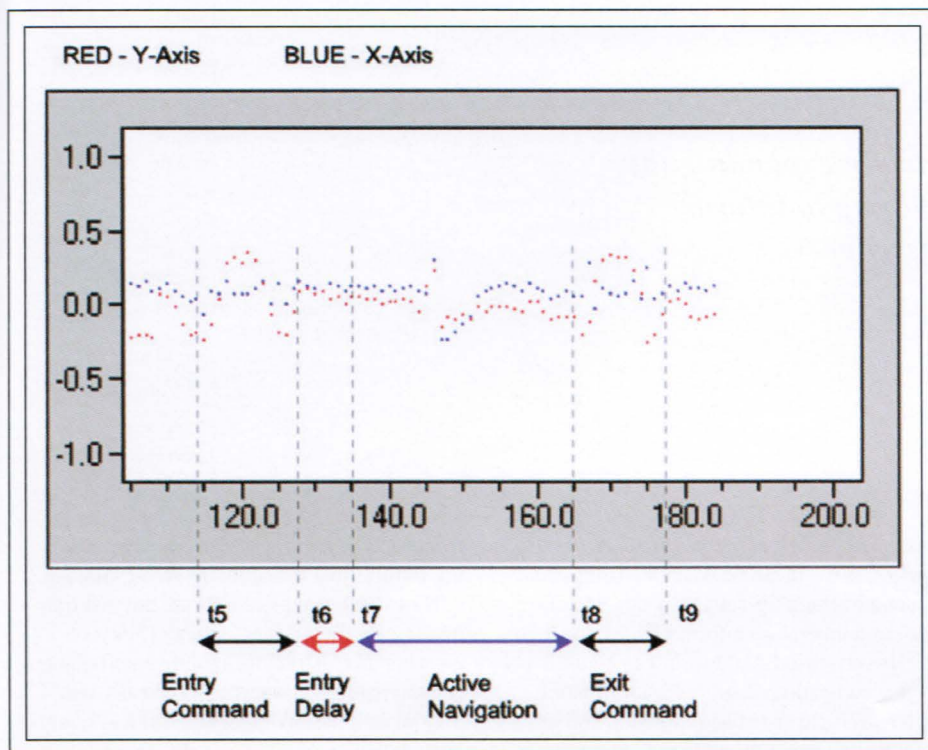

Fig. 4: When the program encounters a gesture corresponding to an entry command, it activates the navigation mode (t5–t6).

non-linearity within certain ranges of its operation, the changing response curves and the user-machine control loop will combine to arrive at the correct view.

Users can select or adjust various stored response curves through set-up or change-on-the-fly. The set-up software can associate different response curves with specific applications.

### Hand Gestures Control Navigation

RotoView utilizes the orientation sensor as a smart switch to enter and exit the navigation mode, thus eliminating the need for a mechanical button. The program assigns unique, predefined hand gestures to various commands, which it identifies by monitoring the orientation sensor's signals. The gestural commands comprise a short set of hand movements, e.g., two consecutive fast rolls, selected so the user can easily initiate a command without activating it inadvertently. While the entry and exit commands may be similar, it is more important to ensure that the entry command is less prone to unintentional activation.

When the program encounters a gesture corresponding to an entry command, it acti-

vates the navigation mode (Fig. 4). (The figure is a screen capture from our development system showing the raw sensor data from a dual-axis accelerometer.) The entry command is identified between times t5 and t6. The display remains fixed for a short entry delay until time t7 to allow the artifacts of the entry hand gesture to subside.

The program exits the navigation mode in response to another predefined hand gesture, shown between times t8 and t9. However, by time t9, when the exit command is fully recognized and acted upon, the navigation program may inadvertently alter the final image that was displayed at t8. To solve this problem, a dynamically stored trail of previous navigation states allows the program to restore the view selected just prior to the changes made by the exit hand gesture.

We have also developed two other methods (selected by a set-up routine) to automatically exit the navigation mode. The first method sets a fixed time limit for each navigation session, so the user must re-enter the navigation mode if the desired view is not achieved. The second method terminates the navigation

mode when the program can not sense further orientation changes (above the normal noise level) for a preset length of time, presumably because the user has reached the desired view. The benefit of the automated exit methods is the elimination of the exit command. However, since these methods may terminate the navigation session before the user reaches the desired location, the re-entry mechanism should be a quick and intuitive single-handed operation.

### Development Path

Cost improvements are essential for a technology aimed at popular low-cost mobile devices. Improvements in the response algorithm tend to reduce the need for expensive accurate sensors.

We have recently seen a major reduction in the cost of MEMS accelerometers. Thus far, we have tested RotoView as an external add-on device, so our implementations have included the costs associated with the external interface circuitry. We believe that the technology will be commercially viable when the sensor is interfaced directly within the core electronics of the hand-held device's chipset. The new low-cost MEMS accelerometers require only a two-channel A/D converter for interfacing.

In the course of development, we have created alternate methods to achieve various aspects of view navigation and control. The methods with the best chance of successful commercial implementation are those that are the most intuitive and user-friendly for average users. This will require extensive testing involving a large number of users, followed by proper surveys, to build a good database for determining the best methods.

While in recent years we have seen the emergence of combined PDA and communications devices, there are still at least three major platforms – based on the Palm, Windows CE (Pocket PC, SmartPhone), and Symbian operating systems – suitable for RotoView enhancement. This diversity of mobile operating systems and hardware choices requires the simultaneous development of several core solutions. ■

## Road Show

*New technologies and applications are expanding the role of displays in automobiles, helping to inform and entertain both drivers and passengers.*

by Robert L. Donofrio

**A**DVANCES in display technology are changing the ways in which we interact with information in our daily lives. Most of us think of displays in terms of televisions, mobile phones, computer monitors, PDAs, and other electronic devices. It is easy to overlook – but not overstate – the importance of display technology in automotive applications.

The migration of consumer electronics to vehicles also creates the need for new control and distribution systems, such as a digital network for audio/visual systems. This network can be used to support additional devices and functions, including computers and PDAs, as well as information from sources outside the vehicle, such as global positioning systems (GPS), entertainment, and data services.

Displays are used in at least six distinct locations in vehicles (Fig. 1). The most obvious is the instrument cluster; this usually includes a speedometer, tachometer, and odometer, along with oil, temperature, and battery gauges or warning lights. A second location is the center console, typically home to the stereo sound system; GPS; shifting information; heating, ventilation, and air-conditioning (HVAC); and warnings about open doors. The rear-view mirror is a third position, where a compass, a GPS direction pointer, and even a “backing up” camera

image can occasionally be found. A fourth position is overhead between the front seats, where a backing-up-camera image, a compass, or temperature information can be seen. The driver’s windshield itself can be used as a projection head-up display for information such as vehicle speed and direction and infrared (IR) images of possible road hazards. Finally, there is growing interest in displays for the back seats which may be located in the back of the center console, in the back of the

front seats or their headrests, or even in ceiling fixtures that may fold down for viewing.

New display applications are not just limited to new-model cars, either. There is a growing aftermarket for mobile entertainment and navigation products that typically use 5–9-in. cathode-ray tubes (CRTs) and liquid-crystal displays (LCDs).

Automotive applications place special demands on displays. Most installation positions require up to 50–55° (horizontal) view-



*Robert L. Donofrio is President of Display Device Consultants, 6170 Plymouth Rd., Ann Arbor, MI 48105-9531; telephone 734/730-3116, fax 734/665-4211, e-mail: donofrio@comcast.com.*

**Fig. 1:** From backseat entertainment to driver information systems, displays play an increasing role in automotive design.

Optrex America

ing angles. Panels mounted where they are subject to higher ambient-light levels require greater luminance in order to maintain acceptable contrast – up to 40% more than for panels mounted in more sheltered locations, such as overhead consoles. Other factors to consider include operating and storage temperatures – automobiles can get very hot or cold under normal conditions – durability, and special user-interface features including touch screens.

### The View from Above

Clearly, there are abundant opportunities for making use of displays in the automobiles of today and the near future. According to Dr. Kimberly Allen of iSuppli/Stanford Resources, the worldwide market for flat-panel displays (FPDs) in automotive applications was \$906 million in 2001 and is projected to grow to \$1.3 billion in 2006 (Fig. 2). Sales of vacuum fluorescent displays (VFDs) and light-emitting-diode (LED) displays that are often used in character displays are expected to decline slightly as they continue to be replaced by passive-matrix LCDs and organic light-emitting-diode (OLED) displays. The total number of active-matrix LCDs (AMLCDs) will increase from the 2002 value of \$8.6 million to \$21 million in 2006.

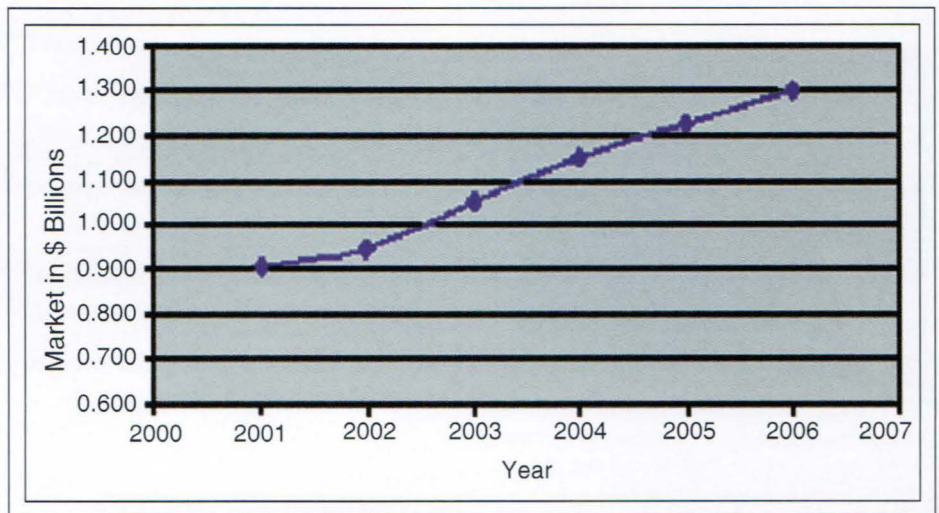

iSuppli/Stanford Resources

**Fig. 2:** The automotive-display market worldwide is expected to show steady growth through 2006.

It is important to point out that iSuppli/Stanford Resources tracks only information displays and not backlights. As a result, the actual dollar value for the entire system would be higher.

In addition to the shift away from VFDs and LEDs toward LCDs, AMLCDs, and OLED

displays, the automotive industry is moving toward larger, more versatile displays (Fig. 3). Instrument-cluster and center-console displays are expected not only to convey more information at one time, but to be configurable to show different types of information at different times. The growth in popularity of backseat entertainment systems is rapidly increasing the demand for display sizes in the medium (5–8-in.) range. There is also growing interest in large displays (9 in. and larger).

For the near future, most of these mid- and large-sized displays will be LCDs; but in spite of the rapid growth in demand, this will remain a small portion of the overall LCD market. The total LCD revenues in 2000 were \$22.4 billion, and by 2006 they will reach about \$53 billion, at which point all automotive displays are expected to account for just \$1.3 billion.

Some additional market-research data from Strategic Analysis (via Philips Mobile Display Systems) shows greater demand for rear-seat entertainment systems. They project that 1.6 million rear-seat entertainment units will ship in 2006, compared with just 250,000 in 2002. This more than sixfold increase will be driven largely by demand in the U.S. domestic market.

DisplaySearch predicts that automotive-display shipments in 2006 will be about triple those for 2002. The company also anticipates that high-resolution color OLEDs will make their appearance in OEM automotive displays by 2004.

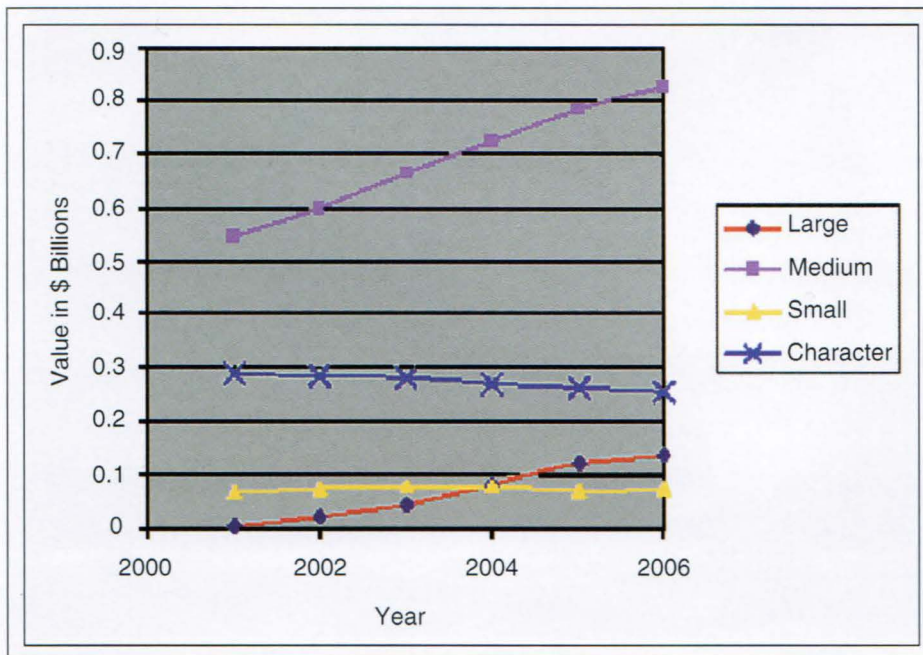

iSuppli/Stanford Resources

**Fig. 3:** Most of the market growth will take place in the medium-sized-display segment, although large displays will increase significantly.

## automotive displays



Yazaki

**Fig. 4:** Anti-reflective coatings on the VFD in this center-console application help reduce reflections from ambient light.

### From the Driver's Seat

In order to take the pulse of this essential market segment, we contacted many of the major automotive-display suppliers to get an update on where they are headed.

**Optrex America.** Located in Plymouth, Michigan, Optrex is a leading supplier of displays to the automotive industry. In 1981 and 1982, Optrex made the world's first LCDs in instrument clusters for the Mitsubishi Cordia and Honda Accord. The company recently started an LCD-component assembly plant in Plymouth, Michigan, that uses their standard cold-cathode-tube (CCT) fluorescent lamp for backlighting. In May 2002, Optrex licensed OLED technology from Eastman Kodak Co. for use in passive-matrix OLED displays.

**Yazaki North America.** Yazaki's North American headquarters is located in Canton, Michigan. The Yazaki multimedia display is a 5.8-in. 16:9-aspect-ratio wide color AMLCD with 640 × 350 pixels. The panel luminance is 380 cd/m<sup>2</sup>, with viewing angles of ±60° horizontal and ±45° vertical, and an operating-temperature range of from -30 to +85°C.

The Yazaki Toyota Prius display uses a VFD with an anti-reflective (AR) coating – made with a sol-gel process rather than standard evaporation methods – for the instrument cluster (Fig. 4). The display can thus be exposed to more ambient light and still maintain good contrast.

Yazaki has shown concept instrument clusters with a two-color 1 × 2-in. 128 × 64-pixel VFD rated at 1000–2000 cd/m<sup>2</sup>. The

company also showed a Kodak color active-matrix OLED information panel of the same size, with 512 × 218 pixels and 150 cd/m<sup>2</sup>. For the 2007 model year, they will have a 7-in. 16:9-aspect-ratio monitor with a Sharp color LCD for backseat entertainment, featuring a wireless network, Web browser, Windows CE operating system, and support for DVD players and other entertainment devices.

**Johnson Controls.** Johnson Controls had \$20 billion in sales in 2002. They employ 77,000 persons (with about 6000 of them in engineering design and research and development) in 290 locations in 30 countries. In Michigan, Johnson Controls has display-related facilities in the cities of Plymouth and Holland. The company uses more than 6 million LCDs and 3 million VFDs each year.

The Johnson Control's center-console LCD is a multifunction display used for the radio, clock, and temperature readouts. Twisted-nematic (TN) and supertwisted-nematic (STN) LCDs are used for segmented displays. Film-compensated (FSTN) or double-film-compensated (FFSTN) LCDs are used for dot-matrix displays, and AMLCDs are used for video applications. Some LCDs use an LED backlight, in which light from amber, green, and white LEDs are distributed to the panel

using a light guide. The Johnson Controls center-stack display is used by Renault and PSA and in the Nissan *Primera*. The top-of-the-line product is a full-color AMLCD used for navigation and rear-seat entertainment. The company also uses LCD panels to display images from a rear-facing camera to help the driver back up the vehicle (Fig. 5).

For the future, Johnson Controls engineers are paying attention to OLED technology but do not expect it to be in mass production for automobiles until 2007 or 2008. They also see the possible use of projection displays as soon as 2006; Johnson Controls is working with Microvision to develop a microelectromechanical (MEM) laser-projection system for both monochrome and full-color displays to compete with LCDs and VFDs.

**Durel.** Display backlighting becomes essential in applications that cannot rely on ambient lighting for the illumination of a reflective LCD. New environmental standards for mercury-free lighting are pushing display-backlight technology away from the traditional CCT lamps and towards Xe fluorescent lamps and other backlight technologies, including OLEDs, LEDs, and electroluminescent (EL) technologies. EL displays employ either thin films, such as those in



Johnson Controls

**Fig. 5:** An LCD panel mounted in an overhead console can provide images from a rear-facing camera to assist the driver when backing up the vehicle.

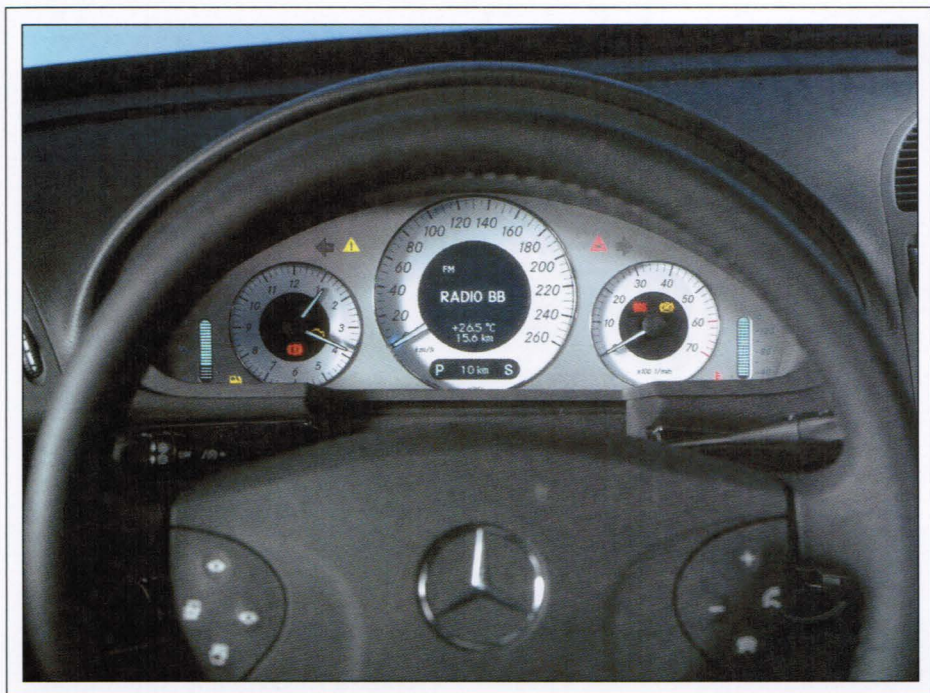

Durel/Siemens VDO

**Fig. 6:** Thick-film EL backlights such as these used in a Mercedes console can provide lighting for LCD panels.

Denso's ACTFEL and Planar's EL displays, or thick films, such as those in the backlights made by Durel for the Siemens VDO instrument clusters used in the Mercedes E-Class and CLK models in 2003 (Fig. 6).

In the Mercedes instrument cluster, a floating ring needle is attached to a stepper motor, leaving the center display unobstructed. The Durel EL panel replaces the conventional LED or CCT backlighting for the LCD. According to a Durel representative, one EL backlight can replace 6-8 incandescent bulbs or LEDs in an automotive instrument cluster, thus reducing the number of parts and simplifying fabrication.

**Philips Mobile Display Systems.** Representatives from Philips Mobile Display Systems see the emergence of the full-graphics display in the automotive industry for audio, message center, and entertainment, using AMLCDs, STN-LCDs, and polymer OLEDs (POLEDs). Philips makes LCD modules for JCI, Visteon, and Delco, and also works directly with some auto companies. The ruggedizing techniques used to make LCDs for the Space Shuttle and Boeing 777 aircraft help improve the displays made for automobiles.

Philips Mobile Display Systems has demonstrated a new 7-in. AMLCD that is targeted at backseat entertainment and automotive infotainment applications.

**Luxell and Hyundai LCD.** Luxell and Hyundai LCD have reported that they soon will have a 2.1-in. passive-matrix monochrome OLED display for handheld and automotive applications, expected to be available in 2003.

#### The Road Ahead

The Information Age has extended its reach into all facets of modern life, including the automobile. From navigation and systems information, to sound and video entertainment, to new modes of communication, the need for information display throughout the average automobile is growing rapidly. Existing and new technologies are helping engineers design dashboards and consoles that present new information in powerful and accessible ways. The result will be better-informed drivers and better-entertained passengers, which will translate into a safer and more enjoyable travel experience. ■

# 15

03

## SEPTEMBER

*The 23rd International Display Research Conference (IDRC 2003)*

PHOENIX, ARIZONA  
SEPTEMBER 15-18, 2003

- An international conference on display research and development aspects of:
- Display Materials (liquid crystals, small-molecule and polymer OLEDs, phosphors, optical compensation films, flexible substrates, etc.)
- Display modeling, Design and Processing
- Display Systems and Human Interfaces

# 17

03

## AUGUST

*The 8th Asian Symposium on Information Display (ASID '03)*

NANJING, JIANGSU, CHINA  
AUGUST 17-20, 2003

- The Asian Symposium on Information Display (ASID), originated from the joint Japan-Korean information display conference, has become one of the major regional information-display conferences sponsored by SID. The purpose of the conference is to provide a friendly and collegiate environment for display researchers, especially in the Asian region, to present their work and exchange information. ASID '03 covers all aspects of display science and technology.

# SID '04

Symposium, Seminar,  
and Exhibition

Seattle, Washington

Washington State  
Convention and Trade Center

May 23-28, 2004

# Active-Matrix LCDs for Mobile Telephones in Japan

*The increasingly sophisticated functions of modern mobile telephones require the use of more advanced displays, and the Japanese market leads the way.*

by Ryoichi Watanabe and Osamu Tomita

**O**VER the last few years, liquid-crystal displays (LCDs) for mobile applications have improved remarkably in pixel count, brightness, color range, and other characteristics as well. The LCDs used in products such as notebook PCs, personal digital assistants (PDAs), digital video cameras (DVCs), and, especially, mobile telephones, are required to have small size, low weight, ruggedness, and low power consumption. And, of course, they must have high image quality. Because markets for portable telephones are increasing rapidly all over the world, the development of LCDs for mobile telephones is proceeding more rapidly than the development of LCDs for other applications.

Mobile telephones are now being used not only for voice communications, but also for a variety of other functions (Fig. 1). Communications speed in the network infrastructure and individual terminals is increasing, and third-generation (3G) communications service became available in Japan in 2001.

*Ryoichi Watanabe is Group Manager of the Cell Design & Engineering Group, Design & Engineering Center, Toshiba Matsushita Display Technology Co., Ltd., Saitama, Japan. Osamu Tomita is Group Manager of the Mobile-Use Marketing & Engineering Department, Mobile-Use LCD Division, Toshiba Matsushita Display Technology Co., Ltd., 1-9-2 Hatara-cho, Fukaya-shi, Saitama, 366-0032, Japan; telephone +81-48-574-5844, fax +81-48-574-2136, e-mail: osamu.tomita@tmdisplay.com.*

In Japan, short mail and the Internet are the most popular advanced services. In March 2002, the number of mobile-telephone Internet subscribers reached 75% of the number of terminals in use. Commercial transactions, such as Internet shopping and banking, and advanced information services, including streaming video, are among the capabilities of these new Internet-capable telephones.

The number of models with built-in cameras is also increasing, and this is making it possible not only to transmit and receive both static and dynamic images, but also to implement a practical and appealing videophone. These advanced functions require the display of not only characters, but of photographs, maps, and moving pictures. To perform these functions effectively, advanced mobile telephones require higher-performance LCDs,

and display performance is improving dramatically.

## Trends in LCD Mobile Applications

**Display mode.** Color displays were already dominant in mobile phones in Japan during the first half of 2001 (Fig. 2). The figure shows the percentage of the number of color-LCD models in the Japanese market. By the second half of 2001, the majority of these color displays were AMLCDs; by the second half of 2002, 100% of the mobile phones sold in Japan contained color AMLCDs. This trend suggests that the advanced functions included in mobile phones required color AMLCDs for effective implementation.

In the first half of 2001, transmissive displays sharply outnumbered reflective and transmissive displays in mobile telephones,

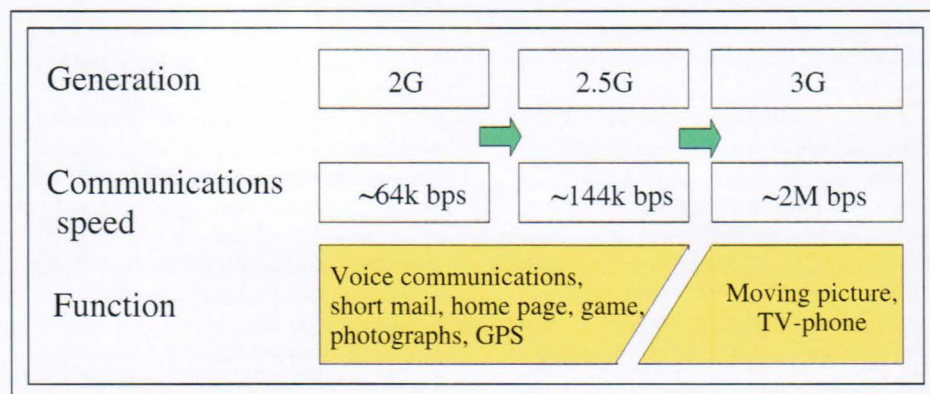

**Fig. 1:** Increases in communications speed make possible more advanced mobile-telephone services, which require more-capable displays.

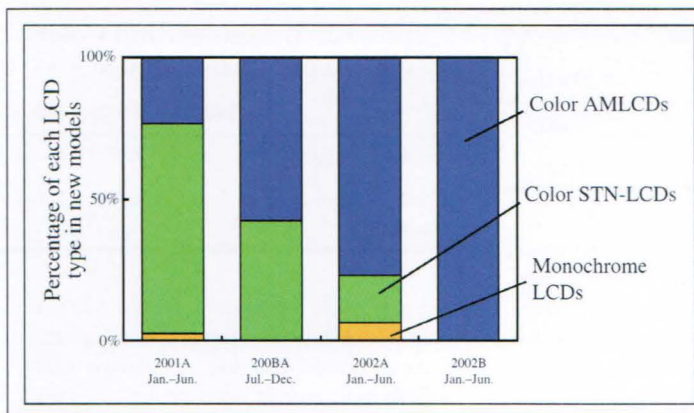

**Fig. 2:** Color AMLCDs had displaced all other display technologies in the Japanese mobile-telephone market by the second half of 2002.

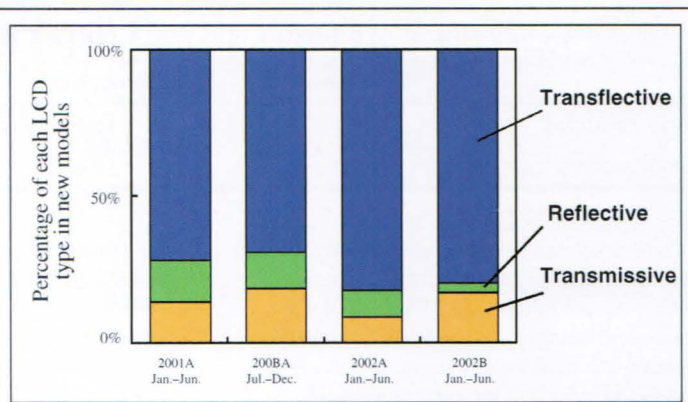

**Fig. 3:** Transflective displays have dominated the Japanese mobile-telephone market since at least the beginning of 2001.

and the transflective optical mode has become even more dominant since then (Fig. 3). The ascendancy of the transflective optical mode is a direct consequence of its good contrast ratio in both bright and dark ambient-light conditions (Fig. 4, Table 1). Transmissive LCDs exhibit high contrast ratios in dark ambients, but under bright light, such as direct sunlight, their visibility decreases. Reflective LCDs have good visibility in bright ambient-light conditions, but exhibit poor visibility in dark ambient-light conditions. Reflective LCDs can display images in bright ambients without either a backlight or frontlight, offering low power consumption in such conditions. Transflective LCDs are well balanced,

and have good visibility in both bright and dark ambients.

**Display performance.** The number of pixels in supertwisted-nematic (STN) and active-matrix LCDs installed in mobile telephones is increasing (Fig. 5). In the first half of 2001, the most common pixel counts were in the range of  $101 \times 122$  to  $120 \times 160$ ; in the first half of 2002, they were in the range of  $128 \times 160$  to  $144 \times 176$ . For displays with approximately 2 in. diagonals, this works out to be a pixel density of about 110 ppi.

How high should pixel density go? Because the normal human visual acuity is one minute of arc, most persons would not be able to resolve pixels spaced more densely

than 200 ppi at a viewing distance of 40 cm (16 in.), which is a reasonable distance for cellular-telephone use. Therefore, it is reasonable to assume that the pixel format of 2-in.-class LCDs will increase to  $240 \times 320$  (QVGA). Indeed, QVGA displays began to appear in the product mix during the second half of 2002.

Both luminance and color reproduction of mainstream panels, *i.e.*, transflective AMLCDs, increased every 6 months beginning in the first half of 2001 through the first half of 2002 (Table 2). Over this period, the luminance increased from 30 to over  $100 \text{ cd/m}^2$ , and the color-reproduction range increased from about 10% to about 40% of the

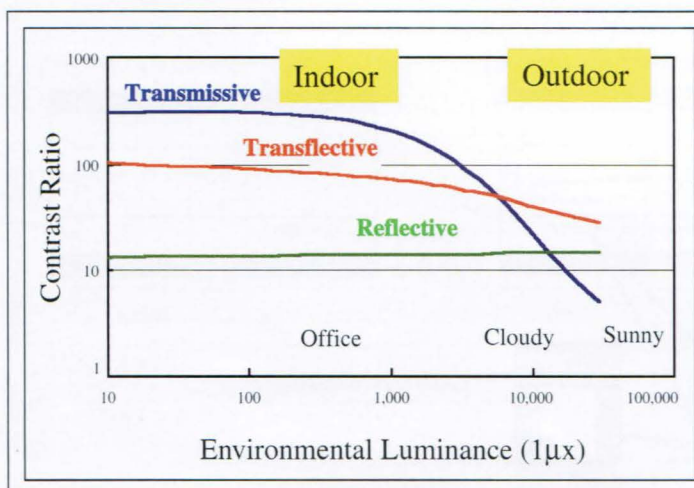

**Fig. 4:** The popularity of transflective displays is due to the fact that they exhibit a good contrast ratio under all ambient-illumination conditions.

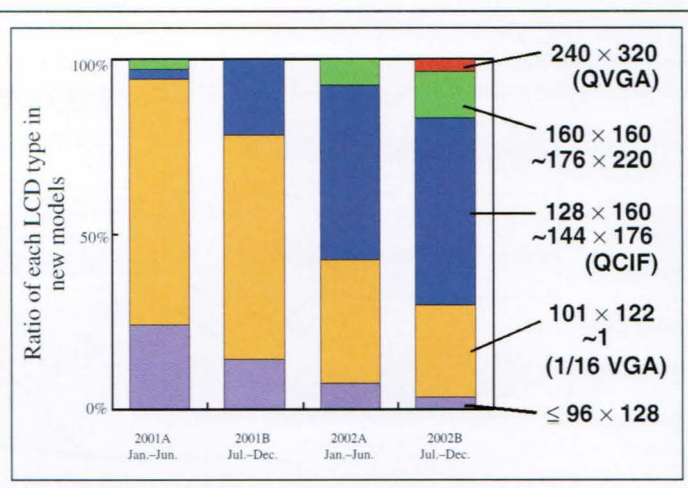

**Fig. 5:** In the Japanese market, QVGA displays entered the product mix for mobile telephones during the second half of 2002, and are likely to dominate in the future.



# mobile-telephone displays

**Table 1: Ambient Light and Contrast Ratio**

	Transmissive	Transflective	Reflective
Bright ambient	Poor	Good	Good
Dark ambient	Excellent	Good	Fair

NTSC color gamut. Some models have nearly the same values as those in typical notebook PCs, with a luminance of 150 cd/m<sup>2</sup> and a color-reproduction range of 50%. We believe that further performance improvements will be required for moving-picture applications such as television.

### LCD Cell Structure

As previously indicated, three optical modes are in use (Fig. 6). In the reflective-LCD cell, a polarizer and retarder are stacked on the front side of the cell, and the cell is filled with liquid-crystal material [Fig. 6(a)]. The reflector is formed inside the cell. The structure produces a high aperture ratio and parallax-free images.

The requirements for the inner reflector are high reflectance and achromaticity, and the reflected light must be diffused. There are two approaches to diffusing the light. One approach is to combine a specular reflector

with a diffusing layer, while the other is to use a reflector with dimples that produces both reflection and diffusion from a single layer. The former method results in higher productivity; the latter results in better control of the diffusion.

If the dimples in a dimpled reflector are arranged in a regular lattice, an optical-interference pattern can be generated in bright sunlight, resulting in decreased visibility. If the location of the dimples is randomized, the optical interference can be decreased. An effective way to position the dimples is by using a Fibonacci series, which produces an arrangement that is random along any axis.

The upper side of the cell incorporates a frontlight system which is used as an auxiliary source of illumination. This provides enough illumination to ensure legibility even in very dark ambients.

The cell structure of transflective LCDs features a polarizer and retarder, both in the

**Table 2: Brightness and Color-Reproduction Range**

	2001A	2001B	2002A
Luminance (cd/m <sup>2</sup> )	30	30~50	30~160
Color-reproduction range (%)	5~10	10~15	15~40

front and rear, and a backlight attached to the rear [Fig. 6(b)]. Two types of pixel structures have been used to realize transflective LCDs. One is a half-mirror structure and the other is a structure that divides the pixels into separate transmissive and reflective areas, so that transmissive and reflective performance can be optimized independently. This optimization is performed with multi-color-filter and multi-gap structures.

Multi-color-filter technology was developed to solve a significant and well-defined problem in divided pixel cells. Initially, standard color filters were used with divided-pixel-cell transflective displays. This was fine for the transmissive part of the pixel because light passed through the color filter only once, just as in traditional transmissive displays for which such filters had originally been designed. But, in the reflective part of the

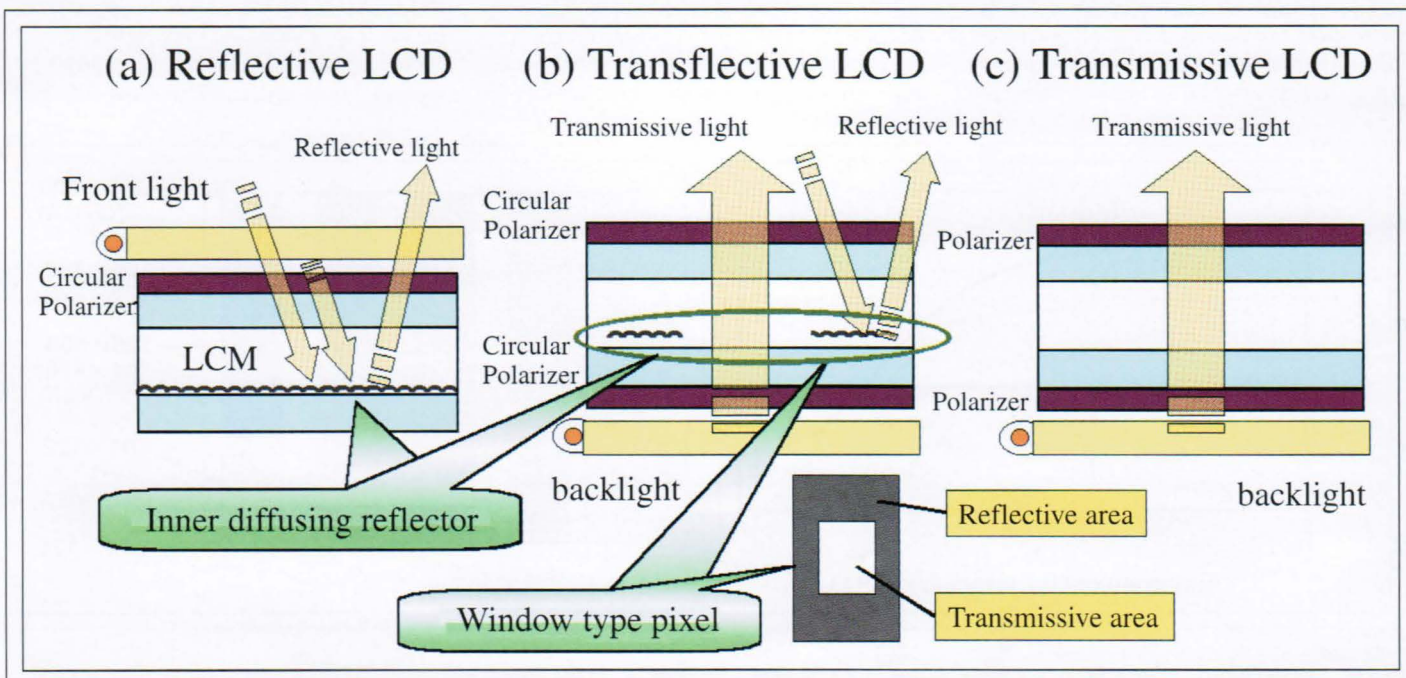

**Fig. 6:** Shown are the cell structures of the three optical modes used in LCDs for mobile telephones.

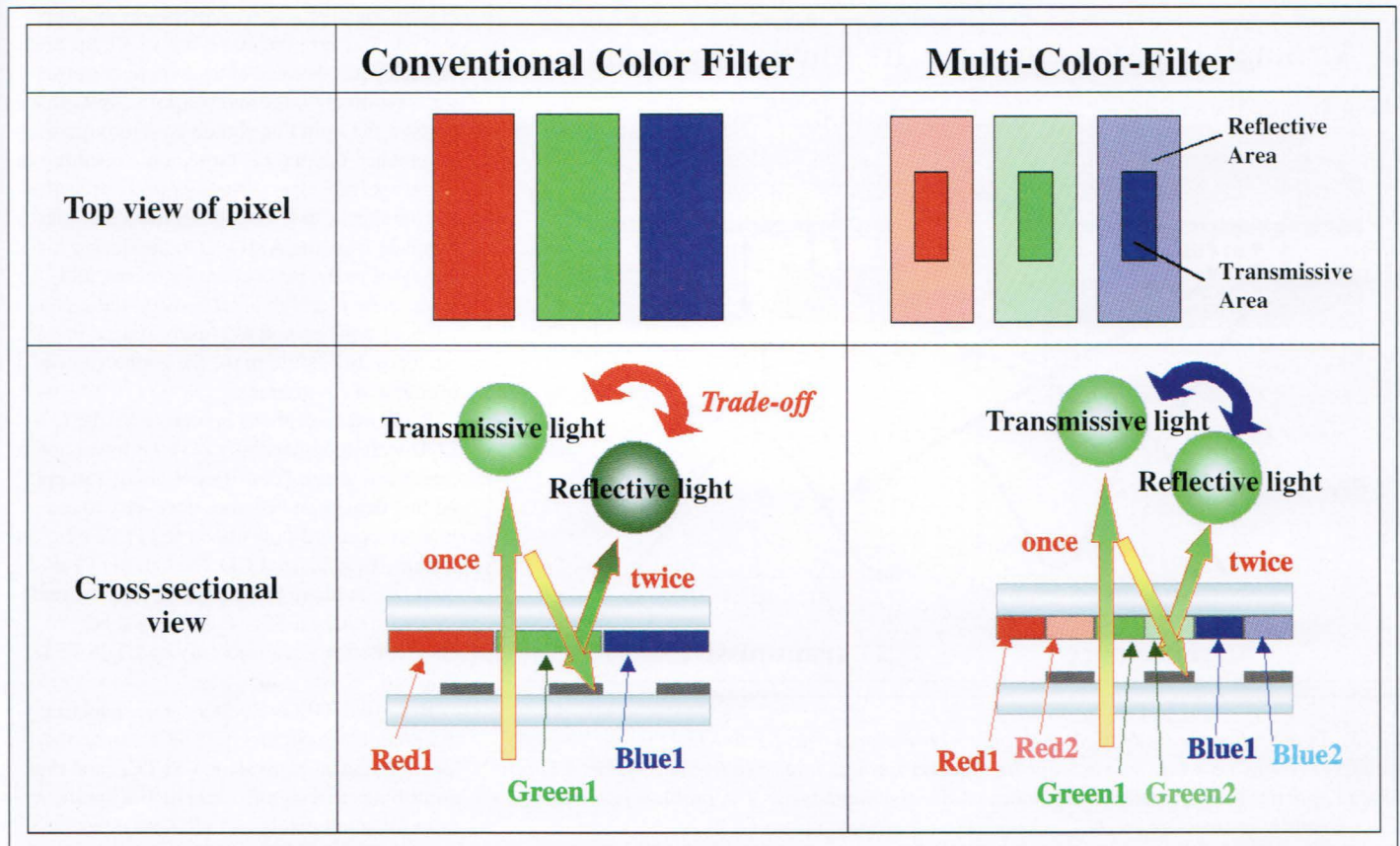

**Fig. 7:** In the reflective mode, light entering a conventional transfective LCD passes through the LCD layer twice, while transmissive light passes through it once (left). This makes it impossible to optimize the performance of the two modes simultaneously. The problem is solved by using a multi-gap structure (right).

pixel, the reflected light passes through the color filter twice, with the result that twice the light is absorbed and the display appears much darker in the reflective mode than in the transmissive mode. If we try to solve this problem by reducing the optical density of the color filter, the colors in the transmissive part of the pixel will be insufficiently saturated, *i.e.*, they will be pale.

Multi-color-filter technology is the solution to this problem (Fig. 7). The color filter for each subpixel is divided into two sections, a low-density area for the reflective part of the pixel and a higher-density area for transmissive part. In this way, the color saturation and transmittance of the two areas can be optimized independently rather than being traded off one against the other.

A parallel problem arises with the effective cell gap in transfective displays. A critical design parameter in determining the performance of an LCD is the cell gap, the thickness

of the gap between the upper and lower plates of an LCD, which is filled with liquid-crystal material. In the reflective part of a transfective-LCD pixel, the light traverses the gap twice, so the gap is effectively twice as large as the gap in the transmissive part, even though it is geometrically the same size. The solution is multi-gap technology, which allows the cell gap to be optimized independently for the reflective and transmissive parts of the cell (Fig. 8).

The third type of cell structure used in LCDs for portable applications is the transmissive mode [Fig. 6(c)]. This is essentially the same as the transmissive mode used for notebook-PC and desktop monitors, and is therefore very familiar.

#### Resolution

When a manufacturer sets out to make a high-resolution AMLCD – an LCD with a relatively large number of small pixels packed

**Table 3: Specifications of a 2.2-in.-diagonal QVGA LCD**

Number of pixels	240 × (RGB) × 320 (QVGA)
Panel size	2.2 in.-diagonal
Resolution	180 ppi
AMLCD device	LTPS TFT
Optical mode	Transfective
Transmittance	5%
Reflectance	5%
Color-reproduction range (NTSC ratio)	40%
Contrast ratio (transmissive)	80
Contrast ratio (reflective)	20

# mobile-telephone displays

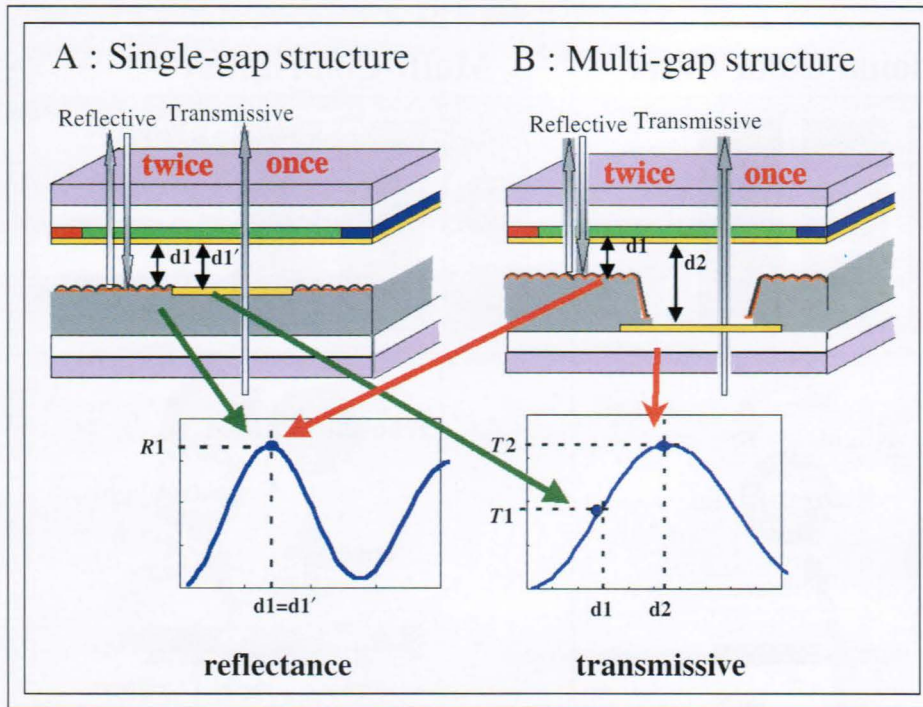

Fig. 8: In the reflective mode, light entering a conventional transreflective LCD passes through the LCD layer twice, while transmissive light passes through it once (left). This makes it impossible to optimize the performance of the two modes simultaneously. The problem is solved by using a multi-gap structure (right).

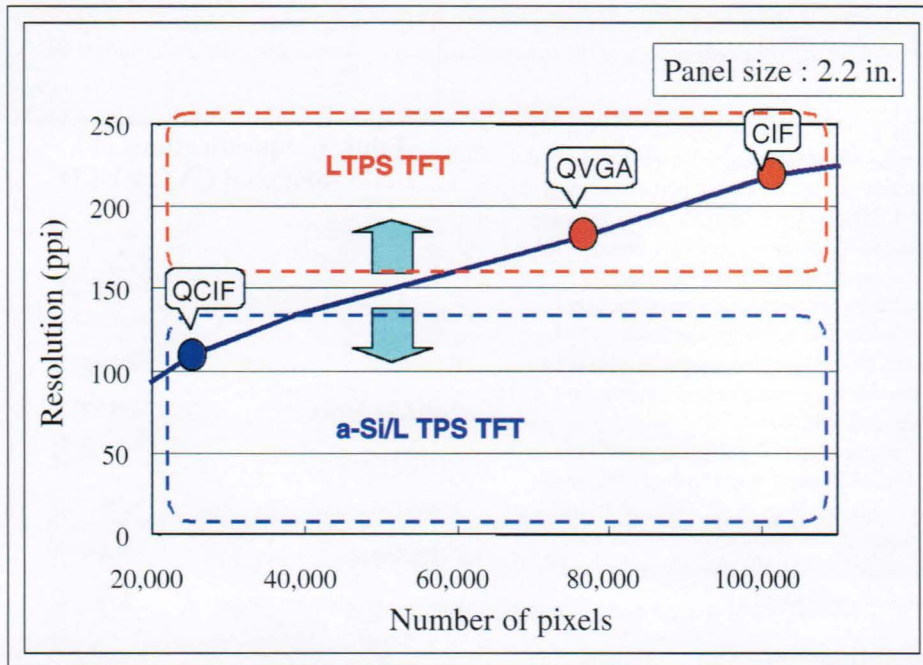
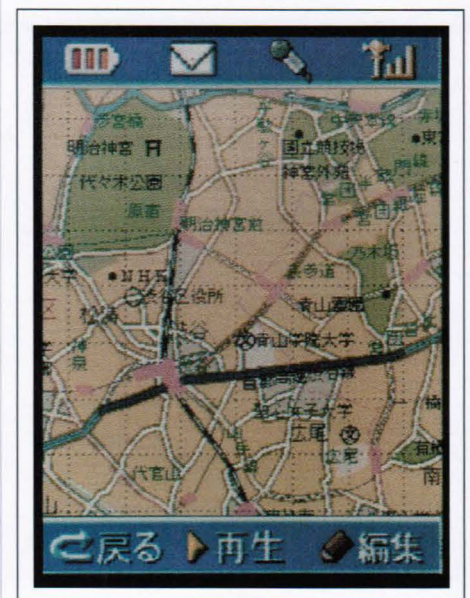

Fig. 9: As pixel density exceeds 150 ppi, it becomes necessary to use low-temperature-polysilicon (LTPS) TFTs instead of amorphous-silicon (a-Si) TFTs.

closely together – several problems must be solved. Because the pixels are small, the area of each pixel devoted to its switching transistor is relatively large and blocks a substantial parts of the light that should pass through the pixel when the pixel is turned on – resulting in a low aperture ratio. Another problem is that the number of external connections that must be made from the AMLCD to the device increases as the pixel count increases, and when there is a high pixel density, these connections can become so closely spaced that it becomes difficult to make the connections in a production environment.

Standard amorphous-silicon (a-Si) TFT-LCD technology begins to exhibit lower aperture ratios at pixel densities of about 150 ppi. At that density, it becomes necessary to use low-temperature-polysilicon (LTPS) TFTs. In the case of a 2.2-in. LCD, the Quarter Common Intermediate Format (QCIF) can be realized with either a-Si or LTPS TFTs, but QVGA is easily realized only by LTPS TFTs (Fig. 9).

Because LTPS is a better semiconducting material than a-Si, an LTPS TFT can be much smaller than an equivalent a-Si TFT, and thus contributes to a significantly higher aperture ratio for small pixels. LTPS is even fast



Toshiba Matsushita Display Technology Co., Ltd.  
Fig. 10: Toshiba Matsushita Display's 2.2-in.-diameter QVGA transreflective display for mobile telephones has 180 ppi and uses LTPS TFTs.

enough to be used to integrate some circuits directly on the display glass. Integrating digital-to-analog converter (DAC) circuits or signal-selector switches on the glass can substantially reduce the number of external connections compared to an a-Si TFT-LCD, which requires the same number of connections as it has signal lines. So, LTPS TFTs can achieve easier fabrication and better connection reliability.

**A QVGA LCD for Mobile Telephones**  
At Toshiba Matsushita Display Technology, we have developed a QVGA LTPS TFT-LCD (Fig. 10, Table 3). The 2.2-in.-diagonal panel has 76,800 pixels and a pixel density of 180 ppi, which results in the high-quality reproduction of detailed images such as maps. The display's transfective mode provides good visibility in both bright and dark ambients.

Although QVGA displays such as this one just began to emerge in the second quarter of 2002 as part of the product mix for mobile telephones in the Japanese market, we are convinced that they represent the future of mobile telephones. The high quality of the mobile telephones is the result not only of improvements in the communications infrastructure and mobile-terminal technology, but also of the continuous improvement of LCDs.

## SID '04

Symposium, Seminar,  
and Exhibition

Seattle, Washington

Washington State  
Convention and Trade Center  
May 23-28, 2004

Please send new product releases or news items to Information Display, c/o Palisades Convention Management, 411 Lafayette Street, 2nd Floor, New York, NY 10003.

# 17

03

## AUGUST

*The 8th Asian Symposium  
on Information Display  
(ASID '03)*

NANJING, JIANGSU, CHINA  
AUGUST 17-20, 2003

• The Asian Symposium on Information Display (ASID), originated from the joint Japan-Korean information display conference, has become one of the major regional information-display conferences sponsored by SID. The purpose of the conference is to provide a friendly and collegiate environment for display researchers, especially in the Asian region, to present their work and exchange information. ASID '03 covers all aspects of display science and technology.

# 15

03

## SEPTEMBER

*The 23rd International  
Display Research Confer-  
ence (IDRC 2003)*

PHOENIX, ARIZONA  
SEPTEMBER 15-18, 2003

• An international conference on display research and development aspects of:  
• Display Materials (liquid crystals, small-molecule and polymer OLEDs, phosphors, optical compensation films, flexible substrates, etc.) • Display modeling, Design and Processing • Display Systems and Human Interfaces

# LOOKING for Anti-Reflective Film?

### ESI OFFERS:

- **AR FILM** - Multi-Layer Anti-Reflective Coating on PET or TAC
- **AR/AG FILM** - Multi-Layer Anti-Reflective Coating with "Non-Glare" Matte Surface on PET

\* All films available with or without pressure sensitive adhesive.

### ESI ALSO OFFERS:

- ANTI-REFLECTIVE GLASS AND ACRYLIC
- OPTICALLY BOND SUBSTRATES
- PRIVACY FILTERS
- EMI/RFI SHIELDING
- IR BLOCKING FILM
- HIGH VOLUME LAMINATION CAPABILITIES
- SUBCONTRACT MANUFACTURING

Custom filters and display enhancing optical films to meet all of your needs.

348 CIRCUIT STREET • HANOVER, MA 02339  
PHONE: 781-829-0808  
www.eyesaverinternational.com



**IDEAL R&D/QC for Advanced TV Sets**

 **ASTRO**

**Programmable Video Signal Generator**

**VG-849**

- \* Supports all DTV formats
- \* Output can be fully Programmable
- \* HDMI/ HDCP/ DVI Interlace
- \* ANALOG RGB/ YPbPr/ S-Video/ Composite



**Other Products:**

**VG-828:** Hybrid Video Signal Generator Supporting Analog RGB/YPbPR and Digital TMDS/ HDCP and TTL.

**VG-848:** Wideband clock range, Supports broadband output of 165MHz MAX with frequency setting accuracy at levels as high as 1 dot (analog only) along with 5 to 250MHz analog / 25 to 250MHz digital.

**VG-847:** VG-847 is a multi-format TV signal generator for analog output based on NTSC, PAL, SECAM, SMPTE-293M, 296M, and 274M.

**VA-1807:** Protocol Inspection Unit used to inspect the functions of a HDCP supporting display monitor.

**IDEAL R&D/ QC for Display Components**

**Programmable Video Signal Generator**

**VG-835**

- \* Wideband Output of 100KHz up to 300MHz
- \* It is fully programmable
- \* Available you will have 4 X LVDS outputs and TTL for maximum application usage.



**Other Products:**

**VG-845:** Supports up to 100 MHz in the parallel output 1/1 clock mode (0.5 to 25 MHz with low bandwidth specification), and up to 200 MHz in the 1/2 clock mode.

**VG-827:** Is a compact, lightweight and low-cost portable video signal generator that maintains compatibility with analog output video generators.

**VG-826A:** Provides up to 8 bits of RGB digital outputs and low-voltage digital serial outputs (panel link or LVDS), it supports XGA-class (in the 1/1 clock mode) and SXGA-class (in the 1/2 clock mode) timings.

[www.astro-systems.com](http://www.astro-systems.com) (877)-88-ASTRO(27876) [info@astro-systems.com](mailto:info@astro-systems.com)



## Everyone has a vision.

First you dream it. Then you do it. We dreamed of creating superior touch screens.



And we did it by combining MicroTouch™ Technology with Vikuiti™ Display Enhancement Films. The result is touch displays that are brighter, whiter and more



colorful. What's your vision? Visit [www.3M.com/Vikuiti](http://www.3M.com/Vikuiti) or [www.3Mtouch.com](http://www.3Mtouch.com) today.

## Letter to the Editor:

In the February 2003 issue of *Information Display*, you reported on your visit to Kent. In this article you mentioned that the first spin-off of LCI (Liquid Crystal Institute) was Kent Displays in 1993 and that the founders were Bill Doane and William Manning. I would like to bring to your attention that I was also one of the co-founders and managed the company from its formation until the end of 1995. You should know better!

At the end of 1995, the current management of Kent Displays initiated a legal dispute that is still continuing until today. Many times we discussed how harmful all these prevalent legal fights are to the American display industry. The final result is the colossal decline in the American display manufacturing capabilities and loss of many good jobs.

By the way, I graduated with a 4.0 grade average from Kent State University, received the Student Research Award from the Sigma Xi Society in recognition of outstanding scientific research in cholesterics, and Bill Doane was my thesis advisor.

Please make the necessary corrections and publish my remarks in the magazine as a letter to the editor.

*Best Regards,*  
*Zvi Yaniv*

**Response:** A source within Kent Displays confirms that Dr. Yaniv was one of the company's founders. I apologize for the omission.

– KIW

## Letter to the Editor:

This note comments on A. H. Bergman's article on the F!T CRT display in the October 2002 issue of *Information Display*. In juxtaposition with Tom Holzel's "Can Anyone Profit from Selling Wall TVs" in the November issue, it serves to highlight the fact that there is no FPD of adequate performance at an affordable cost so as to enable the transition to digital HDTV. Prices of shadow-mask CRTs for HDTV also are too high; and so the transition has stalled. However, the F!T article presents an image generated by a complete display at adequate luminance. So, removing the shadow mask can be made to work. In fact, it provides the only alternative currently on the

scene for the advancement now expected of consumer TV.

It may be beneficial to put the "maskless" color CRT in perspective. The textbox on page 13 of the October issue of *ID* compares a F!T tube to an index tube. But the F!T tube is an index tube. Its basic mode – phosphor triad tracking – appears in more than a few of the over 300 U.S. patents in the class which covers indexing. Some, such as those from major consumer electronics companies, received publicity. Another, with no publicity, had substantial investment by a major tobacco company. Index patents had to show conformity to the NTSC scan direction, but today's technology allows operation at any scan sequence.

The important comparison, which the diagram makes, is the method of color separation. The separation, or selection, generally associated with "indexing" is sequential color separation (SCS). It was pointed out in "End of the Shadow Mask" (*Information Display*, June 1998) that the failure of the "indexing" revival of the 1980s was due to the poor performance of SCS. Its peak currents must be substantially higher than is indicated in F!T. These comparisons, detailed in the *Journal of the SID* (Vol. 6, No. 4, 1998) were made to dynamic color separation (DCS), which was introduced to put CRT performance back where it belongs.

DCS is a broad concept encompassing methods of implementation that cover the full range of CRT scanning options. It accommodates to three-beam, as well as to single-beam operation. Some methods bridge between two versions of color separation. Thus, with three beams, F!T color compares to conventional shadow-mask scan and signal processing, but with an improved performance approaching DCS.

The five-times reduction in beam-current density is substantially more important than the manipulation of beam astigmatism in reducing electron repulsion. If beam elongation is to reduce peak cathode current, it must be by increased cathode area. In this respect, cold-cathode versions (such as that described in "A Novel Electron Source for CRTs," *Information Display*, June 2002) should be of special interest because the cathode area can be fitted to match the pixel. In that example, with a high electron exit-velocity range, the resultant high astigmatism can be corrected.

All versions of DCS and F!T (slightly modified) can have equal H and V resolution

(square pixel). Then, the important factor is that the pixel's modulation transfer function (MTF) response is near 100% – not the limiting 5% of the shadow mask (and CRT projection). That gives a 2–3 times increase in perceived detail and with performance comparable to the FPD limit and to HDTV's ultimate promise.

Finally, signal processing is generally not more complicated in these systems. It is different but equivalent.

NTSC has served well for almost 60 years. It is past time for change, and it is important that new signal standards have clear consideration of CRT behavior.

*Clayton A. Washburn*

**Response:** According to *ID*'s sources, Philips had serious intentions of commercializing the F!T tube, but, ultimately, when capital expenses and (as it turned out) the minimal improvement in overall TV system cost were considered, Philips decided that the program could not be justified.

– KIW

## Letter to David Lieberman

What is horizontal and what is vertical? That's a non-trivial question we stumbled over yesterday, and maybe it is an interesting topic for your column in *Information Display*.

[I am not] a native English speaker, but that's not the problem. We were talking about keystone correction. In the past, only trapezoidal distortions from upward projection could be corrected, so that was "keystone correction." Now our company Liesegang electronics GmbH, as well as Pixelworks and Silicon Optix, is able to correct distortions from upward and sideward projection.

[So] the projection world [now] has to decide how to name these two corrections. One is "horizontal keystone correction"; the other is "vertical keystone correction." But which one is which? We searched a bit on the Web and could not find an answer, so this is our chance to coin the terms.

To date, the terms are not clearly defined because there exist two views to keystone correction: the user's view and the engineer's view. Let's look at upward projection. The user says, "I correct a distortion from vertical upward projection, so that's vertical keystone correction." The engineer says, "I have to

## letters

manipulate the width of the image, so the algorithm performs horizontal scaling, so that's horizontal keystone correction."

My view is let's just agree on something and, as we are developing technology for the user, let's speak to him in his language. So here's my definition: Vertical keystone correction is the correction of upward projection. Horizontal keystone correction is the correction of sideward projection.

*Best regards,  
Marco Winzker  
Manager, ASIC Design  
Liesegang electronics GmbH  
Hannover, Germany  
e-mail: mwinzker@  
liesegang-electronics.com ■*

## IDRC '03

**International Display  
Research Conference**

**Phoenix, Arizona**

**September 15-18, 2003**

# 4

# 03

## NOVEMBER

*11th Color Imaging  
Conference: Color Science,  
Engineering, Systems &  
Applications*

**SCOTTSDALE, ARIZONA  
NOVEMBER 4-7, 2003**

- An international multidisciplinary forum for dialogue on:
  - Creation and capture of Color Images
  - Color Image reproduction and interchange
  - Co-sponsored with IS&T

# SID '04

## Symposium, Seminar, and Exhibition

## Seattle, Washington

## Washington State Convention and Trade Center

## May 23-28, 2004



**HVT** is your single source for high quality, dependable refurbishment and repair of LCD displays for any application, including computer monitors, cell phones, PDA's and mobile video.

Capabilities include TAB, Flex and Heat Seal Bonding to 50 microns, Polarizer lamination and PCB repair.

**Visit our website:  
www.HVTNET.com  
Email: Sales@HVTNET.com  
770.495.4881  
Fax: 770.495.4885**

### State Of The Art Service Solutions for Today's LCD Display Products

- Manufacturer Warranty Fulfillment
- Contract Assembly
- Logistics Management
- Repair and Return

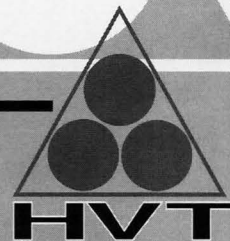

**HONG VIDEO TECHNOLOGY, INC.**



## editorial

continued from page 2

*ID*: But if you are an emerging company, what would make you more attractive to investors?

Ricchiuti: Establish a technology roadmap and milestones, and hit those milestones going six months and a year out. Emerging companies appeal to a very different investor than do established companies. Investors in emerging companies have a larger view than institutional investors, who must show relative safety and quick returns. You saw the crowds here, and that there's a lot of interest. People do recognize the opportunities; there is clearly an appetite. And there is surely a strong end demand for the products.

### Last Story

Microvision made a splash a couple of years back with the Nomad™ retinal scanning display it was developing for the military and later applied to industrial applications. That display used a low-power laser diode, so it was a laser beam that was being scanned across the user's retina. Military personnel are not inclined to say "No, sir" when they are instructed to test a new device, but even some of my intrepid journalistic colleagues were heard to say, "Not in my eye you don't."

In fact, the laser intensity was too low to do any harm, but Microvision realized that if they were to develop their technology for consumer products, those products had better not contain lasers. And they don't. The company's new product generation uses three (non-laser) diodes for full color, and the basic Gen 2 engine is one-fifth the size of that in the original monochrome Nomad; the Gen 3 consumer product will be one-tenth the size (see photograph). President Stephen Willey gave the presentation; afterwards, he and Communications Director Matt Nichols showed me the hardware.

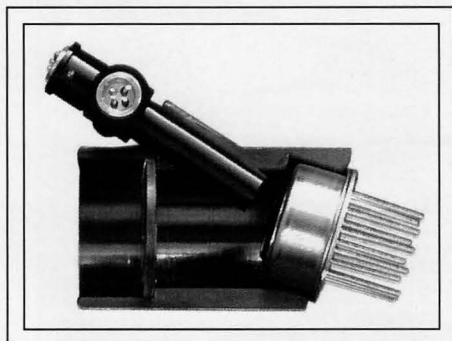

The first major display target is an electronic viewfinder (EVF) for digital still cameras and camcorders that provides an image with desktop quality, unlike all of the EVFs in use today. The initial target price of this full-color module is \$50 to OEMs, and it will become cheaper. Microvision is working with Canon in the second phase of a relationship to develop this product. I was shown a prototype built into a camera, and I was impressed with the image quality and stability.

The core of Microvision's engine is a MEMS device to steer the incoming light beam. If you think about a device containing a single mirror from a Digital Micromirror Device, you will have the general idea. But this mirror traverses in two directions instead of one, and it's larger than the DMD mirrors. Nichols said the device should have infinite lifetime as long as you stay under the shear point of the silicon.

### Exit

The USDC/Needham Conference was an interesting event, and – as you know if you've gotten this far – it gave me a lot to write about without evening mentioning the high-powered keynote addresses or most of the company presentations. But I'll close with one quote from the keynote address by Matt Medeiros, former CEO of Philips Components: "At Philips we should have starved the CRT [of R&D funds] and put that income into AMLCDs. LCD companies must invest in new technologies to move forward."

– KIW

We welcome your comments and suggestions. You can reach me by e-mail at [kwerner@nutmegconsultants.com](mailto:kwerner@nutmegconsultants.com), by fax at 203/855-9769, or by phone at 203/853-7069. The contents of upcoming issues of *ID* are available on the *ID* page at the SID Web site (<http://www.sid.org>).

*Please send new product releases or news items to Information Display, c/o Palisades Convention Management, 411 Lafayette Street, 2nd Floor, New York, NY 10003.*

## backlight

continued from page 48

polymer OLEDs, it crafted an alliance with SEL to develop active-matrix polymer OLEDs. By the end of the year, the company got its legal ducks in a row and signed a cross-licensing agreement with polymer-OLED pioneer CDT. And, meanwhile, back in April of 2001, it had committed \$15 million to build a "market development facility" in Santa Barbara to start seeding the OEM community.

Nor was the company wanting in energy in 2002, putting a number of highly significant new relationships into place while managing the progress of the others. And at the 2002 SID International Symposium, the company demoed polymer OLEDs aplenty: monochrome passive-matrix, monochrome active-matrix, full-color active-matrix, and a flexible passive-matrix on a plastic substrate.

In the spring of 2002, DuPont Displays, in collaboration with Clare, Inc., announced the availability of driver/controller chips specifically designed and optimized for polymer OLEDs. In the fall, the National Institute of Standards and Technology approved a project under the Advanced Technology Program to fund Sarnoff Corp. to collaboratively develop active-matrix OLED technology on plastic substrates with Bell Labs and DuPont. In the winter, DuPont announced an agreement with Varitronix, Ltd., for that Hong Kong display powerhouse to assemble polymer-OLED modules. And finally, as the year closed, it announced a cross-licensing agreement with UDC, along with a joint development agreement "to create a new generation of soluble OLED materials and technology" based on phosphorescent OLEDs.

Now what does DuPont Displays have up its sleeve for 2003? I don't know, but you do. (You are reading this in July – well after the 2003 SID International Symposium, Seminar, and Exhibition has closed its doors – but I am writing it well before the doors will even open.) I am hoping that we might start to get a look at some of the invisible relationships DuPont Displays has been forming in the background, the ones that fit the final pieces of the puzzle into place. The ones with customers. Show me cellular phones, PDAs, and Internet appliances. And show them right next to models with LCDs, please. ■

*David Lieberman is a veteran display journalist living in Massachusetts.*

## Belarus Chapter News

by Alexander Smirnov

During the last technical meeting of the SID Belarus Chapter, held February 27, 2003, Dr. A. Ilyanok, Director of the Atomic and Molecular Engineering Laboratory, presented an interesting lecture on dynamic design in architecture. This presentation was unusual and somewhat surprising, so I decided to share it with the SID community.

Dr. Ilyanok said that the existing tendencies in architecture and construction are based on the harmony of form, figure, and color spectrum. Thus, leading to a design that is static. Therefore, for a change in style or fashion, the reorganization of buildings and room interiors are required, and this leads to significant expenses. So Dr. Ilyanok offered a new concept in architecture: "dynamic" design or the instantaneous change of the external and internal appearance of buildings (without changing the form) at will; that is, the decorating and appearance of a building and its internal rooms is made directly with the help of a computer that has a library of pre-existing images or the user's original models. The computer model of the chosen design can instantly be transferred to the walls and windows of rooms without any expense.

The technical realization of this idea is based on a so-called "architectural" display which takes on the role of electronically controlled "wallpaper" and is made of glass blocks with a covering based on nanotechnology. The size of the glass blocks can vary from 1 up to 10 m<sup>2</sup>, and more. By using such blocks, it is possible to decorate any room without limit to size or form. It is important that the materials and paints used in displays are inorganic and not reduced under solar ultraviolet radiation. The image on such wallpaper is formed under the action of electrically controlled elements. Thus, the energy is consumed only during image creation (approximately 1 J/m<sup>2</sup>). Simultaneously, these glass blocks provide thermal and noise isolation.

There were many questions from the audience. Prof. V. Labunov asked how the proposed technical decision differs from the well known "PDLC windows," which are quite expensive now. What will be the approximate cost? Dr. Ilyanok said "It is a flat color dis-

play of an unlimited format, and its cost will be on the order of \$100 per square meter. Moreover, in contrast to television and computer displays, dynamic architectural displays operate in reflected light under external illumination; that is, they look like color poly-graphic images that do not tire the eyes.

Prof. V. Kourmachev was interested in the additional features of such windows and was informed by Dr. Ilyanok that the architectural displays also operate as electronically controlled filters; in this case, not by the reflection of light, but by the transmission of light. Such a window can carry out two functions. In the afternoon it transmits solar light. During the evening it takes on the role of a light screen reflecting light inside of a room. Additionally, he noted that this window reflects light in the infrared region, so it can sharply reduce thermal losses in weather. In hot weather, it can reflect solar light and prevent the superfluous heating of rooms.

As for me, I have never participated in such a spirited discussion, and I was interested mostly in addressing the technical issues of such an "architectural" display. "Thank you for your detailed answer, Dr. Ilyanok, but let me ask you once again. What kind of nano-structured material are you using?"

He answered by saying "At present, we have developed a new class of inorganic materials. They are controlled by an external electric current and effectively absorb or reflect light. It is very important that in such materials the charge and, hence, the image be maintained. The static image can be displayed for a long period of time. These can be produced only with nanotechnologies that provide the optimization of ergonomic and electrophysical parameters directly at the molecular level. Such materials can completely replace luminofors."

In conclusion, Dr. Ilyanok proposed to radically change the paradigm of large-sized display construction, switching from a matrix-type light-emitting display to flat RGB displays, to one controlled by external reflected light having a frame frequency of over 75 Hz and self-scanning as a regular feature. Existing technologies do not make room for this paradigm, so new principles of physics, as well as advanced technologies, particularly nanotechnologies, must be adopted.

To explore these issues further, Dr. Ilyanok can be reached at [ilyanok@bsu.by](mailto:ilyanok@bsu.by) or by telephone at +375-29-6-55-83-27.

## New SID Senior Members

The SID Senior Member Grade Committee is pleased to announce that the following SID members are newly elevated to SID Senior Member status:

**Dr. David L. Post**, Greater Dayton Chapter  
**Mr. Robert L. Donofrio**, Metropolitan Detroit Chapter

**Mr. Gus F. Carroll**, Bay Area Chapter  
**Mr. Brian H. Berkeley**, Bay Area Chapter

Senior Members are those individuals who are recognized to have made significant technical contributions to the advancement of displays and who have demonstrated active participation in the display community and in SID.

**Shigeo Mikoshiba**, Chair  
**Senior Member Grade Committee**

For those of you who wish to be considered for the Senior Member grade, please click "Senior Member Grade" which can be found under "NEW TO THE SITE" on the SID home page, [www.sid.org](http://www.sid.org). Also, please see *Information Display* 18, No. 11, 30 (2002.)

## SID Texas Chapter Organizes Session at March APS Meeting

The Texas Chapter of the SID coordinated a Focus Session on Nanotechnology for Display Applications during the recent American Physical Society March Meeting in Austin, Texas. This meeting is the largest physics meeting of the year, with an estimated record 5600 talks delivered during the entire meeting. The APS March Meeting is traditionally a showcase for both important fundamental physics and also the type of applied physics that forms the backbone of modern technology.

There were several sessions devoted to nanotechnology; however, this Focus Session, held on March 5, was devoted to the application of nanotechnology for display applications, probably one of the largest markets for immediate commercialization of nanotechnology. The session was anchored by invited presentations from Karl Amundson of E-Ink Corp., speaking on electrophoretic films for electronic-paper displays, and by Michael Paukshto of Optiva, Inc., speaking on thin-crystal-film polarizers. In addition, there were

## SID news

five contributed papers to the session, including three on FED applications. As many as 30 sessions were conducted in parallel to this session. Attendance at the Focus Session was about 35.

**Richard Fink**  
Chair, Texas Chapter

### Richard Fink Receives Texas Chapter Award

It was a pleasure to present Richard Fink the Chapter Service Award of the Texas Chapter of the SID at a Texas Chapter event on January 20, 2003, in Austin, Texas. The award was given in recognition for outstanding service as President of the Texas Chapter and as

organizer of the chapter Nanotechnology Colloquia series that takes place via video conference link between Dallas, Austin, and Houston every other Monday. Richard has also contributed to organizing and serving as editor of the Texas Chapter IP Symposium for the last 4 years. I hope all members join me in congratulating Richard on this achievement and encourage him to continue his contributions to the SID.

**Zvi Yaniv**  
Director, Texas Chapter

## my turn

*continued from page 4*

We industry folks can count pixels until the cows come home, but in the end, I suspect all that most consumers will really care about is the "duck test," to wit: If a TV set has a big screen and can show HDTV programs, it must be an HDTV – right?

**Pete H. Putman** is President of ROAM Consulting, Inc., 200-D North St., Suite D, Doylestown, PA 18901; telephone 215/345-8004, fax 215/345-8007, e-mail: [peteputman@projectorexpert.com](mailto:peteputman@projectorexpert.com), URL: [www.projectorexpert.com](http://www.projectorexpert.com). He is also a senior contributing editor for Primedia Business Media. ROAM Consulting provides training, marketing communications, and product testing/development services to manufacturers of projectors, monitors, integrated TVs, and display interfaces.



**DURALAN II  
A/R™**

**Anti-Reflective Coated Lenses/Filters  
Ideal for Outdoor and Other  
High Ambient Light Applications**

- Developed for Flat Panel Displays
- Improves Light Transmission and Enhances Contrast
- Thicknesses from .010" to .250"
- Custom Fabrications Combine DURALAN II Filter Features
  - EMI/RFI and ESD Protection
  - Excellent Clarity
  - Scratch and Chemical Resistance
  - Custom Graphics
  - Privacy Windows
  - And More...

**SILVER CLOUD**  
MANUFACTURING CO.  
GRAPHICS AND ELECTRONICS

A wholly owned subsidiary of XYMOX® Technologies, Inc.

For additional information call 856/825-8900, fax: 856/825-8969, or visit our web site at [www.silver-cloud.com](http://www.silver-cloud.com)

**Transforming Design Concepts Into Reality**

Circle no. 18

# SID '04

Symposium, Seminar,  
and Exhibition

Seattle, Washington

Washington State  
Convention and Trade Center

May 23–28, 2004

## sustaining members

Acheson Industries, Inc.  
 Ad-Vance Magnetics, Inc.  
 Advance Reproduction Corp.  
 Aerospace Display Systems, LLC  
 AMJ Industries, LLC  
 Amulet Technologies, LLC  
 Applied Concepts, Inc.  
 Astra Products, Inc.  
 ATI Technologies, Inc.  
 AuGRID Corp.  
 AU Optronics Corp.  
 autronic – Melchers GmbH  
 Avery Dennison Microreplication  
 Brewer Science, Inc.  
 Brimar Ltd.  
 Candela Instruments  
 Cando Corp.  
 Canon, Inc.  
 CELCO  
 Chi Mei Optoelectronics Corp.  
 Chunghwa Picture Tubes, Ltd.  
 Ciba Specialty Chemicals  
 ClairVoyante Laboratories, Inc.  
 Clinton Electronics Corp.  
 Corning Incorporated  
 Corning Japan K.K.  
 CYRO Industries  
 Data International  
 DisplaySearch  
 Dontech, Inc.  
 DuPont Displays  
 E-Ink Corp.  
 ELDEC Corp.  
 Electro-Plasma, Inc.  
 Elo TouchSystems, Inc.  
 Endicott Research Group, Inc.  
 ERSO/ITRI  
 Futaba Corp., Product Development  
 Center  
 GDS  
 Gebr. Schmid GmbH & Co.  
 Gennum Corp.  
 GPO Corp.  
 Hannstar  
 Hitachi, Ltd.  
 Hoya Corp. USA  
 Hunet, Inc.  
 iFire Technology, Inc.  
 IMT Masken und Teilungen AG  
 Incom, Inc.  
 Industrial Electronic Engineers, Inc.  
 (IEE)  
 Info Incorporation  
 Innova Electronics, Inc.  
 Instrument Systems  
 Interface Display & Controls, Inc.  
 iSuppli/Stanford Resources, Inc.  
 Japan Patent Office  
 Kent Displays, Inc.  
 LCD Lighting, Inc.  
 LG.Philips LCD

Micronic Laser Systems AB  
 Microvision, Inc.  
 Mitsubishi Electric Corp.  
 Myson Century, Inc.  
 National Semiconductor Corp.  
 NEC Corp.  
 Nippon Seiki Co., Ltd.  
 Noritake Itron Corp.  
 OCLI – A JDS Uniphase Company  
 OES/ITRI  
 Optimax Technology Corp.  
 Optiva, Inc.  
 Optrex America, Inc.  
 PCS, Inc.  
 Photon Dynamics  
 Photo Research, Inc.  
 Picvue Electronics, Ltd.  
 Pioneer Electronics (USA), Inc.  
 Planar Systems, Inc.  
 Plasmaco, Inc.  
 Polar Vision, Inc.  
 Polytronix, Inc.  
 Quanta Display, Inc.  
 Quantum Data, Inc.  
 Reflexite Display Optics  
 ROLIC Research Ltd.  
 ROLIC Technologies, Ltd.  
 Royal Philips Electronics  
 Samsung Electronics  
 Sarnoff Corp.  
 Schott Corp.  
 Sharp Corp.  
 SI Diamond Technology, Inc.  
 Silver Cloud Manufacturing Co.  
 Sony Chemicals Corp. of America  
 Sony Corp. Research Center  
 Supertex, Inc.  
 Symbol Technologies, Inc.  
 Tannas Electronics  
 Thomas Electronics, Inc.  
 Three-Five Systems, Inc.  
 Tiun Yuan Technology Co., Ltd.  
 TLC International  
 Toppoly Optoelectronics Corp.  
 Toshiba America Electronic  
 Components, Inc.  
 Unaxis Balzars, Ltd.  
 UNIGRAF  
 Universal Display Corp.  
 USA EELY-ECW Optoelectronics, Inc.  
 Video Electronics Standards  
 Association (VESA)  
 Viratec Thin Films, Inc.  
 Vishay-Dale Electronics, Inc.  
 VON ARDENNE Coating Technology  
 Westar Corp.  
 WINTEK Corp.  
 ZBD Displays, Ltd.

## index to advertisers

Astro Systems .....36  
 The Bergquist Co.....8  
 CyberTouch .....21  
 Elo TouchSystems .....10  
 Eyesaver International .....35  
 Grand Pacific Optoelectronics.....38  
 Hong Video Technology .....43  
 Jepico America .....6  
 Optical Filters .....39  
 Photo Research .....9  
 Quantum Data.....5  
 Samsung Semiconductor .....C2  
 Silver Cloud Manufacturing Co. ....46  
 Society for Information Display .....40,41  
 3M Optical Systems.....7,17,37,C3  
 VESA .....3,C4  
 Westar Display Technologies.....11  
 Unaxis.....39

### Business and Editorial Offices

Palisades Convention Management  
 411 Lafayette Street, 2nd Floor  
 New York, NY 10003  
 Jay Morreale, Managing Editor  
 212/460-8090 x212 Fax: 212/460-5460  
 jmorreale@pcm411.com

### Sales Office – Europe

George Isaacs  
 12 Park View Court  
 The Paddock, Eaton Ford  
 St. Neots, Cambridgeshire  
 PE19 7SD U.K.  
 Phone/Fax: +44-(0)-1480-218400  
 george@gandg.demon.co.uk

### Sales Office – Japan

Ted Asoshina  
 General Manager  
 Echo Japan Corp.  
 Grande Maison Room 303  
 2-2, Kudan-Kita 1-chome  
 Chiyoda-ku, Tokyo 102-0073 Japan  
 +81-3-3263-5065  
 Fax: +81-3-3234-2064  
 echoj@bonanet.or.jp

### Sales Office – U.S.A.

Palisades Convention Management  
 411 Lafayette Street, 2nd Floor  
 New York, NY 10003  
 Joanne Morgenthal, Sales Manager  
 212/460-8090 x211 Fax: 212/460-5460  
 jmorgenthal@pcm411.com

### Sales Office – Korea

Jung-Won Suh  
 Sinsegi Media, Inc.  
 Masters Tower, Room 2410  
 553, Dowha-dong  
 Mapo-ku, Seoul 121-040 Korea  
 +82-2-313-1951/2 Fax: +82-2-312-7335  
 sinsegi@sinsegi-media.info

### Sales Office – Taiwan

Michael Young  
 Trade Media Representative, Inc.  
 3F, No. 140, San Min Rd.  
 Taipei, Taiwan, R.O.C.  
 +886-2-2763-2438  
 Fax: +886-2-2545-7868  
 mediarep@seed.net.tw

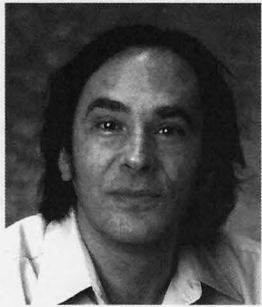

## DuPont Displays: Forcing the Action

by David Lieberman

They say it takes some 25 years to bring display technology to market, and if we point to the first synthesis of conducting polymers in 1977, it appears that polymer OLEDs are right on track. But what a pace lately! The gathering momentum in both polymer and small-molecule OLEDs over the past few years has been a stunning phenomenon to watch, as technologists sprint to the finish line of fielding viable displays. The level of cooperative effort in the quest for OLEDs has also been extraordinary.

Consider DuPont Displays, for example, just one very visible manifestation of the collaborative spirit in the service of greasing the skids to market. Steve Quindlen, President of the OLED Business there, made manifest the company's strategic intent at the 2002 SID International Symposium to "combine the extensive resources available within DuPont with an entrepreneurial approach driven by speed, innovation, and flexibility; [to] assemble a network of engineers, scientists, and technologists from many companies and technical disciplines to bring new display technologies to market faster; [to] consolidate and drive broad-based IP; [and to] become a display provider."

DuPont Displays was born in 2000 as the child of a 198-year-old Fortune 500 company, E. I. duPont de Nemours and Company, a parent with deep pockets and vast technical expertise that could be applied to next-generation displays. From its inception, the operation was geared to force the action in OLEDs and bring this new technology to market quickly, leveraging not just the internal strengths of its parent, but external expertise as well.

And the know-how DuPont Displays tapped into has been extensive, cutting across national boundaries and multiple technical disciplines. A partial list of collaborators includes Alien Technology, Cambridge Display Technology (CDT), Clare, Inc., Covion Organic Semiconductors GmbH, Lucent Technologies' Bell Labs, Osram Opto Semiconductors GmbH & Co., Philips Components, Sarnoff Corp., Semiconductor Energy Laboratory (SEL), Three-Five Systems, Inc., Uniax Corp., Universal Display Corp. (UDC), and Vitex.

The company started its OLED quest in earnest in early 2000 by acquiring Uniax Corp., a 1990 start-up working to commercialize the breakthrough polymer work that had been conducted at the University of California at Santa Barbara. With that solid technical foundation in place, DuPont Displays then set out to put all the pieces of the puzzle in place, forging agreement after agreement as momentum gathered throughout 2001 and beyond, culminating in the shipment of its first polymer-OLED evaluation kits at the end of 2002.

The year 2001 was a stunner. First came the agreement early in the year with Osram Opto Semiconductors GmbH & Co. With this, Osram gained licenses to key Uniax patents as well as a technology transfer of the Uniax manufacturing processes. Shortly thereafter came the critical agreement with RiTEK under which the Taiwanese company began building a high-volume polymer-OLED facility to manufacture displays exclusively for DuPont. And finally, by midyear at the 2001 SID International Symposium, the company announced that it had put two more major relationships in place.

These relationships established both a channel for the present and a road map to the future. For the nonce, DuPont formed a joint venture called Three-D OLED LLC with Three-Five Systems, Inc., to design, assemble, and market passive-matrix polymer-OLED modules. And for coming generations of

*continued on page 44*

**The 8th Asian Symposium on Information Display (ASID '03).** Contact: Southeast University, Electronic Engineering Dept., Nanjing, Jiangsu, 210018 China, telephone/fax +86-25-3363222, URL: www.asid03.seu.edu.cn.  
**August 17-20, 2003** Nanjing, China

**The 12th International Symposium on Advanced Display Technologies & Flowers, 2003.** Contact: SID HQ, 408/977-1013, fax -1531, e-mail: office@sid.org.  
**August 25-27, 2003** Moscow, Russia

**The 23rd International Display Research Conference (IDRC '03).** Contact: Ralph Nadell, PCM, 212/460-8090 x203, fax -5460, e-mail: Rnadell@pcm411.com.  
**September 15-18, 2003** Phoenix, AZ

**The 10th Annual Symposium on Vehicle Displays.** Contact: Mark Goldfarb, PCM, 212/460-5460 x202, e-mail: mgoldfarb@pcm411.com.  
**October 13 and 14, 2003** Detroit, MI

**The 3rd SID/MAC OLED Research & Technology Conference.** Contact: Mark Goldfarb, PCM, 212/460-5460 x202, e-mail: mgoldfarb@pcm411.com.  
**October 24, 2003** New Brunswick, New Jersey

**The 11th Color Imaging Conference: Color Science, Engineering, Systems & Applications.** Sponsored by IS&T and SID. Contact: SID HQ, 408/977-1013 fax -1531, e-mail: office@sid.org, www.sid.org.  
**November 4-7, 2003** Scottsdale, AZ

**The 10th International Display Workshops (IDW '03).** Contact: SID HQ, 408/977-1013, fax -1531, e-mail: office@sid.org.  
**December 3-5, 2003** Fukuoka, Japan

**SID 2004 International Symposium, Seminar & Exhibition.** Contact: Mark Goldfarb, PCM, 212/460-8090 x202, fax -5460, e-mail: mgoldfarb@pcm411.com.  
**May 23-28, 2004** Seattle, WA ■

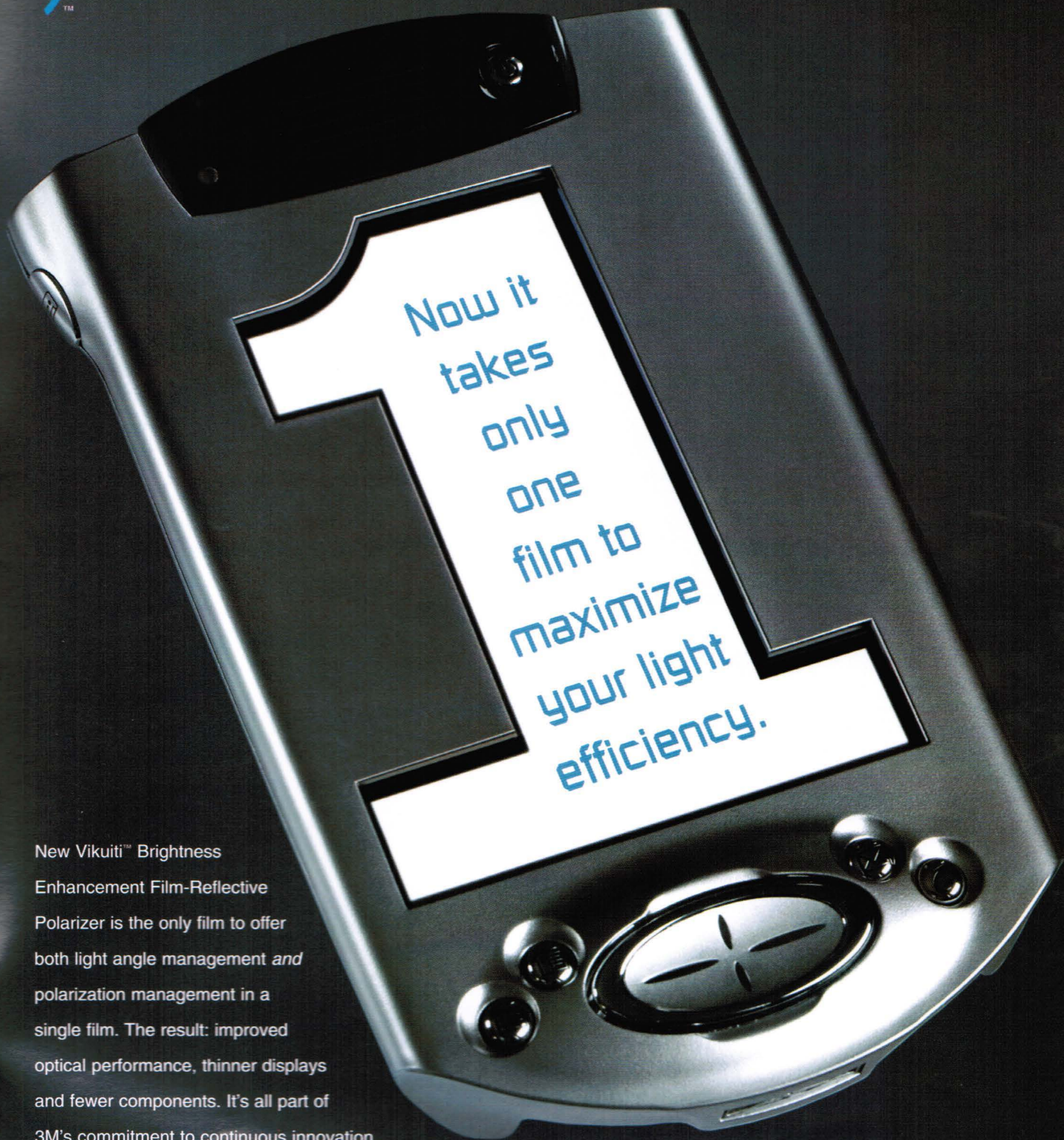

New Vikuiti™ Brightness Enhancement Film-Reflective Polarizer is the only film to offer both light angle management *and* polarization management in a single film. The result: improved optical performance, thinner displays and fewer components. It's all part of 3M's commitment to continuous innovation.

1-800-553-9215 or [www.3M.com/Vikuiti](http://www.3M.com/Vikuiti)

One film. Two jobs. Many benefits.

Circle no. 19

**3M** Innovation

© 3M 2003

# Guarantee your competitive edge.



## Current Committees

Display  
Display Metrology  
Digital Packet Video Link  
Japan  
Microdisplay

VESA Committees are currently creating standards that will cover several areas, including: advanced and packetized video interfaces, multi-display, mobile digital display, flat display mounting interfaces and Plug and Play enhancements.

Be there at the beginning. Participate in the development of ground-breaking display industry standards with VESA's (Video Electronic Standards Association) international team of industry experts.

## First ones to know

Join over 120 member companies from around the world who already benefit from advanced knowledge of new technology standards.

As a member, you are invited to take part in monthly committee and workgroup meetings, or simply be the first to access resulting technical papers and industry standards.

## Display industry leaders

Steadfastly dedicated to innovation and market growth, VESA members lead through their visionary efforts to develop and promote open standards.



# VESA

See our virtual trade show at [VESA.org](http://VESA.org)